

Description and Operation

Edwards Tone Generator and Speaker/Amplifiers are intended for industrial applications where high audible output and microcomputer reliability are required. Catalog Series 5532M ending with suffixes -AQ, -24AQ, -Y6 or -24Y6 are CE Marked. Additionally, the Adaptatone Millennium series are UL and cUL Listed as Audible Signal Appliances for use in the following hazardous locations.

Catalog Number	Hazardous Locations	Temp. Code
5532M-AQ	Class I, Div. 2, Groups A, B, C, D Class II, Div. 2, Groups F, G Class III, Div. 1 and 2	T4 (135C)
5532M-N5		T5 (100C)
5532M-Y6		
5532MHV-AQ		
5532MHV-Y6		
5540M-485Y6	Class I, Div. 2, Groups A, B, C, D Class II, Div. 2, Groups F, G Class III, Div. 1 and 2	T4 (135C)
5540MV-485Y6		T5 (100C)

The 5532B Speaker/Amplifiers are UL Listed and CSA Certified as Audible Signaling Appliances.

The 5532M-Y6 is additionally UL Listed in a Speaker and Amplifier category, when powered with 120V/240V AC 50/60 Hz, for use in conjunction with the 5541M-Y6 Millennium System Master either for emergency/evacuation, non-fire, or for supplementary fire alarm control panel accessory applications (see Instructions for 5541M-Y6, part 3100471).

The Tone Generator operates from local power. It accommodates up to four normally-open contacts on its inputs. The tone that sounds in response to an active input is determined by setting miniature programming switches inside the unit. Figure 19 has switch settings for setting tones.

Four tones may be programmed into the Tone Generator at any time. These tones operate on a pyramid-type priority system. The tone programmed on SW1 overrides the tones programmed on SW2, SW3, and SW4. The tone on SW2 overrides the tones programmed on SW3 and SW4. Likewise, the tone on SW3 overrides the tone programmed on SW4. The tone programmed on SW4 has the lowest priority and cannot override any other programmed tone.

Speaker/Amplifiers are heavy-duty, stand-alone signaling devices that operate from local power and sound a tone programmed at the Tone Generator. Speaker direction and the output level are easily adjustable.

Specifications

Weight - Tone Generator 6 Pounds (2.7 kg)
Weight - Speaker/Amplifier 9 Pounds (4.1 kg)

Hazardous Locations, UL Standard UL1604

Ambient Temp. +41F to +104F (+5C to +40C)

Non-Hazardous Locations

Variable Ambient Temp. -40F to +151F (-40C to +66C)

Hazardous Locations and Variable Ambient Conditions apply only where UL listings are accepted and do not apply to either CE conformity or TUV-Rheinland Certification.

Electrical Specifications

Catalog Number	Input Board		Main Power		
	Voltage	Current	Voltage	Current (A)	
				Standby	Tone On
Tone Generator					
5540M-485Y6	24V DC	6 mA	125V DC**	0.10	0.21
5540MV-485Y6			250V DC**	0.02	0.10
			120V AC 50/60 Hz	0.10	0.32
			240V AC 50/60 Hz	0.10	0.20
Speaker/Amplifier - Standard Volume					
5532M-AQ			24V DC	0.10	0.74
			24V AC 50/60 Hz	0.10	1.3
5532M-N5			120V AC 50/60 Hz	0.10	0.36
5532M-Y6			125V DC**	0.10	0.21
			250V DC**	0.02	0.10
			120V AC 50/60 Hz	0.10	0.32
			240V AC 50/60 Hz	0.10	0.20
5532B-AQ			24V DC	0.06	0.69
			36V DC	0.07	0.84
			24V AC 60 Hz	0.26	1.36
			24V AC 50 Hz	0.26	1.36
5532B-N5			120V AC 60 Hz	0.10	0.29
			120V AC 50 Hz	0.09	0.29
5532B-Y6			125V DC**	0.05	0.16
			250V DC**	0.04	0.10
			120V AC 60 Hz	0.10	0.29
			240V AC 60 Hz	0.11	0.23
			120V AC 50 Hz	0.09	0.29
			240V AC 50 Hz	0.10	0.22
Speaker/Amplifier - High Volume					
5532MHV-AQ			24V DC	0.10	1.5
			24V AC 50/60 Hz	0.10	2.3
5532MHV-Y6			125V DC	0.10	0.39
			250V DC	0.02	0.19
			120V AC 50/60 Hz	0.10	0.56
			240V AC 50/60 Hz	0.10	0.34
5532BHV-AQ			24V DC	0.06	1.51
			36V DC	0.07	1.98
			24V AC 60 Hz	0.26	1.86
			24V AC 50 Hz	0.26	1.86
5532BHV-Y6			125V DC	0.05	0.25
			250V DC	0.04	0.23
			120V AC 60 Hz	0.10	0.62
			240V AC 60 Hz	0.11	0.33
			120V AC 50 Hz	0.09	0.62
			240V AC 50 Hz	0.10	0.33

*5532M-Y6 is suitable for use with 120/240V AC Main Power input in conjunction with the 5541M-Y6 Millennium System Master either for emergency/evacuation, non-fire, or for supplementary fire alarm control panel accessory applications (see instructions for 5541M-Y6, part 3100471).

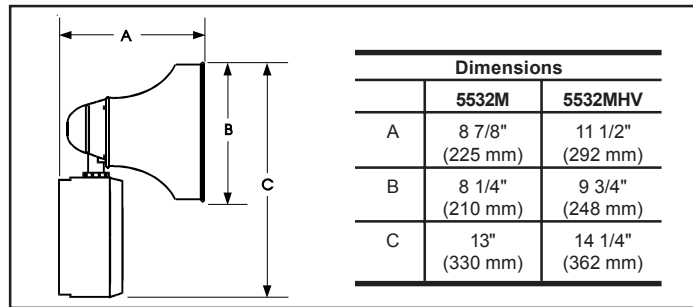

Figure 1. Speaker/Amplifier Dimensions

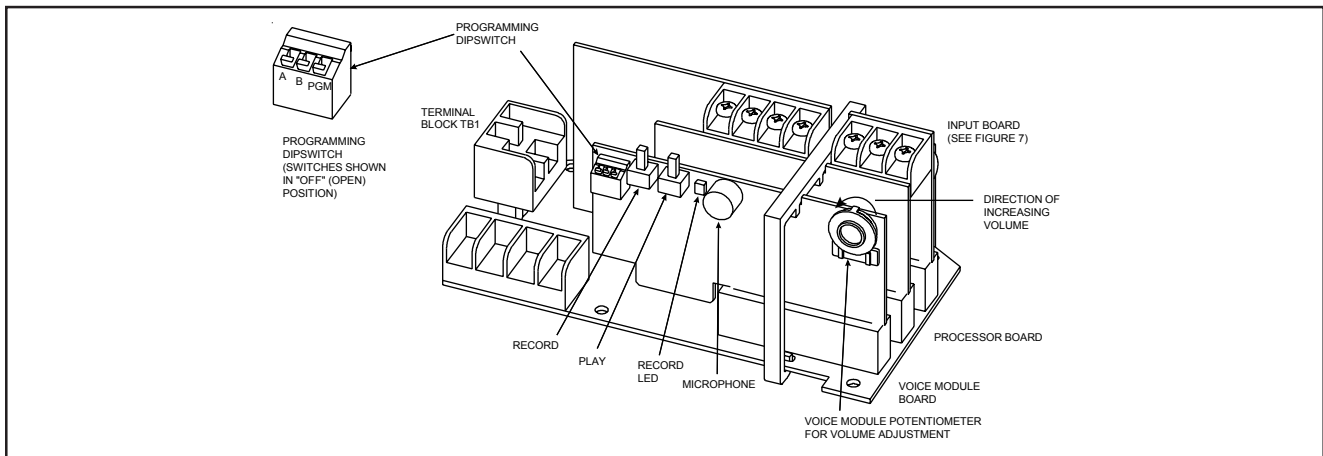

Figure 2. Voice Module Board

Recording a Voice Message (5540MV-485Y6)



WARNING

High voltage is present when product is energized.

Four five-second messages (or one twenty-second message) can be recorded on the voice module unit. Refer to Figure 2.

1. Put switches A and B on the programming dipswitch in the proper position for the message to be recorded

Message Location	Start	Switch Settings	
		A	B
1	0 Sec.	ON	ON
2	5 Sec.	OFF	ON
3	10 Sec.	ON	OFF
4	15 Sec.	OFF	OFF

(Figure 2). For programming a message longer than five seconds, use Message Location 1.

2. Put switch C on the programming dipswitch in the "ON" position for programming mode (Figure 2).
3. Press and hold the record button while speaking clearly into the microphone to record your message. Release the button when recording is complete.

4. To test the message, press and hold PLAY while in programming mode.

NOTE: This will play only the current location.



WARNING

High volume may cause harm to personnel in close proximity.

5. Adjust the volume as necessary. Set the main volume using the potentiometer on the main board (Figures 13, 14 and 15) and then set the voice volume using the potentiometer on the voice module board (Figure 2).

Installation

The Adaptatone may be mounted to any flat surface or may be used as a freestanding unit mounted to a rigid pipe. The Adaptatone must be installed in accordance with the latest edition of the National Electrical Code or other regulations applicable to the country and locality of installation and by a trained and qualified electrician.

NOTE: The increased resistance due to long wire runs needs to be accounted for in sizing wire. Consult Applications Engineering for details.

For catalog numbers ending in "AQ," 24V AC power must be transformer isolated from mains or line power.



CAUTION

During installation, care must be taken so that components on the printed circuit board are not damaged.

1. Mount Adaptatone as shown in Figure 3.
 - a. **Flat Surface Mounting.** Secure unit to mounting surface using the (4) mounting holes in the mounting plate on the rear of the box. Use the #10 x 3" (76 mm) wood screws (furnished loose) or other hardware (not supplied) suitable for the mounting surface.
 - b. **Rigid Pipe Mounting.** Loosen the (4) cover screws from the signal box and lift off signal box cover.

NOTE: Cover screws are captive. Do not remove from cover.

Remove the center knockout in lower wall of box and mount box to a 1/2" (12.7 mm) conduit pipe using suitable connector.

2. Install wires through a knockout hole in the bottom of the box from a raceway that is, with its connections to the 1/2" (12.7 mm) conduit knockout hole, approved for the same degree of protection and enclosure type needed by the application. Use the provided plastic tie-wrap, on the barrier to the electronics, to separate incoming power leads from signal and tone initiating leads, per NEC (Figures 4, 5 and 6).



WARNING

To prevent fire and shock, wire the Adaptatone only as described in this installation instruction.

3. Wire the 5540M Series Tone Generator referring to Figures 4 and 5 as follows:
 - a. Connect green and yellow-striped earth-ground wires to earth-ground.
 - b. Connect the RS485 wires to terminals +TX/RX and -TX/RX on the RS485 COMM board (Figure 5).
 - c. If using the optional MR201/C relay, connect the relay to +RELAY and -RELAY on the RS485 COMM board (Figure 5).

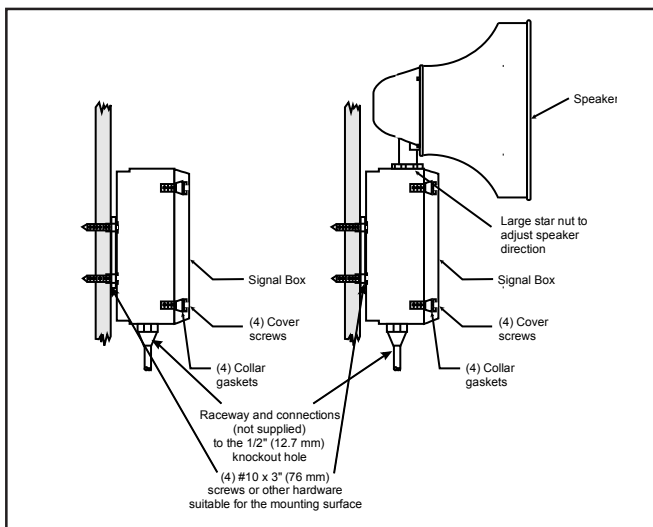

Figure 3. Adaptatone Mounting

- d. Connect incoming power to wire leads using a butt splice or other method listed, certified, or otherwise approved by local authorities. Leads are black and white.
- e. Optional. Connect external 24V DC battery (not supplied) in series with separate diode assembly part 2600010 (supplied) to TB1 terminals 3 and 4 on the main board as shown in Figures 4 and 5 and marked on the diode assembly.

NOTE: Terminal Block TB1 can be unplugged from the main board to complete wiring as shown in Figure 4.

4. Wire the 5532M series speaker/amplifier as follows referring to Figures 6, 7 and 8:
 - a. Connect green and yellow striped earth-ground wires to earth-ground.
 - b. See Figure 8. Connect audio output (+) from the main board of the tone generator to the AUD (+) terminal on the Speaker/Amplifier Audio Coupler Board. Connect audio output (-) from the main board of the tone generator to the AUD (-) terminal on the Speaker/Amplifier Audio Coupler Board. Use shielded cable and connect braid or drain to earth-ground wire lead of 5540 Tone Generator.
 - c. Connect incoming power to wire leads using a butt splice or other method listed, certified, or otherwise approved by local authorities. Leads are both black for -AQ and -N5 models and are black for line and white for neutral for -Y6 models.
 - e. Optional. Connect external 24V DC battery (not supplied) in series with separate diode assembly part 2600010 (supplied) to TB1 terminals 3 and 4 on the main board as shown in Figure 7 and marked on the diode assembly.

NOTE: Terminal Block TB1 can be unplugged from the main board to complete wiring as shown in Figure 7.

5. Wire to the 5532B series speaker/amplifier as follows and referring to Figures XX:
 - a. Connect green earth-ground wire of speaker/amplifier and green and yellow striped earth-ground wires on tone generator to earth-ground.
 - b. Connect audio output (+) from the main board of the tone generator to the Tone In terminal 9 (+) in the Speaker/Amplifier. Connect audio output (-) from the main board of the tone generator to the Tone In Terminal 10 (-) in the Speaker/Amplifier.
 - d. For 5532B-AQ, 5532BDV2-AQ and 5532BHV-AQ models, connect power source to the Speaker/Amplifiers at TS2. Polarity must be observed for DC models.
 - e. For 5532B-Y6, 5532BDV2-Y6, 5532BHV-Y6, and 5532B-N5 models, connect incoming power to wire leads from power supply. For -Y6 models using a DC source, black wire is positive and white is negative and polarity must be observed. For AC source, black is line and white is neutral.
 - g. Optional. Wire 24V DC battery backup to TS1-1 and TS1-2 of the Speaker/Amplifier per Figure 18 and connect 24V DC battery backup in series with diode assembly part 2600010 (supplied) to TB1

terminals 3 and 4 on the main board of the tone generator per Figure 7. Polarities must be observed.



WARNINGS

HIGH VOLTAGE is present when product is energized. High volume may cause harm to personnel in close proximity.

6. Adjust volume level, if desired, by turning potentiometer located on the main board (Figures 13, 14, 15 and 18) and on voice board (Figure 2).



WARNING

To ensure integrity of the Adaptatone assembly when adjusting the speaker direction, make sure threads in the enclosure remain fully engaged and do not turn speaker more than 360 degrees from the original factory installed position.

7. To adjust speaker direction, loosen large star nut (Figure 3) and turn speaker to the approximate desired position. Retighten nut and turn speaker slightly clockwise until locked into place.



WARNING

To ensure integrity of the enclosure: Ensure the cover gasket, part number P-007549-0069, is adhered into groove at cover perimeter before replacing the signal box cover.



WARNINGS

Ensure that the (4) collar gaskets, part number P-041930-0362, are in place on each cover screw before securing the signal box cover.

When securing cover, start screws by hand, making sure they are threaded into tapped holes in housing bosses before securing with a screwdriver. Torque signal box cover screws to a minimum of 20 in-lbs. This ensures the required tight fit.

8. Tightly secure the signal box cover using (4) retained cover screws.
9. Torque signal box cover screws to a minimum of 20 in-lbs.
10. Verify operability.

Maintenance and Test



WARNING

Ensure that power is disconnected before cleaning inside of unit.

Examine the unit semi-annually for accumulation of dirt. Clean if necessary.

The Adaptatone should be tested annually or as required by the authority having jurisdiction to ensure continuous service.

Protocol

1.0 Setting Unit Address and Network Baud Rate

- 1.1 Locate the 8-position dip switch, S1, on the top edge of the RS485 COMM board (Figure 6).
- 1.2 Unit address range is 00-1F hex. (00-31 decimal). Refer to Table 2.2 for unit address configuration. Set S1 positions 1-5 for the desired unit address configuration.

Table 2.2 Unit Address Switch Configuration

Unit Address		S1-1	S1-2	S1-3	S1-4	S1-5
Hex	Decimal					
00	00	OPEN	OPEN	OPEN	OPEN	OPEN
01	01	CLOSED	OPEN	OPEN	OPEN	OPEN
02	02	OPEN	CLOSED	OPEN	OPEN	OPEN
03	03	CLOSED	CLOSED	OPEN	OPEN	OPEN
04	04	OPEN	OPEN	CLOSED	OPEN	OPEN
05	05	CLOSED	OPEN	CLOSED	OPEN	OPEN
06	06	OPEN	CLOSED	CLOSED	OPEN	OPEN
07	07	CLOSED	CLOSED	CLOSED	OPEN	OPEN
08	08	OPEN	OPEN	OPEN	CLOSED	OPEN
09	09	CLOSED	OPEN	OPEN	CLOSED	OPEN
0A	10	OPEN	CLOSED	OPEN	CLOSED	OPEN
0B	11	CLOSED	CLOSED	OPEN	CLOSED	OPEN
0C	12	OPEN	OPEN	CLOSED	CLOSED	OPEN
0D	13	CLOSED	OPEN	CLOSED	CLOSED	OPEN
0E	14	OPEN	CLOSED	CLOSED	CLOSED	OPEN
0F	15	CLOSED	CLOSED	CLOSED	CLOSED	OPEN

Table 2.2 Unit Address Switch Configuration (Cont'd)

Unit Address		S1-1	S1-2	S1-3	S1-4	S1-5
Hex	Decimal					
10	16	OPEN	OPEN	OPEN	OPEN	CLOSED
11	17	CLOSED	OPEN	OPEN	OPEN	CLOSED
12	18	OPEN	CLOSED	OPEN	OPEN	CLOSED
13	19	CLOSED	CLOSED	OPEN	OPEN	CLOSED
14	20	OPEN	OPEN	CLOSED	OPEN	CLOSED
15	21	CLOSED	OPEN	CLOSED	OPEN	CLOSED
16	22	OPEN	CLOSED	CLOSED	OPEN	CLOSED
17	23	CLOSED	CLOSED	CLOSED	OPEN	CLOSED
18	24	OPEN	OPEN	OPEN	CLOSED	CLOSED
19	25	CLOSED	OPEN	OPEN	CLOSED	CLOSED
1A	26	OPEN	CLOSED	OPEN	CLOSED	CLOSED
1B	27	CLOSED	CLOSED	OPEN	CLOSED	CLOSED
1C	28	OPEN	OPEN	CLOSED	CLOSED	CLOSED
1D	29	CLOSED	OPEN	CLOSED	CLOSED	CLOSED
1E	30	OPEN	CLOSED	CLOSED	CLOSED	CLOSED
1F	31	CLOSED	CLOSED	CLOSED	CLOSED	CLOSED

- 1.3 RS485 COMM supports 1200, 2400, 9600 and 19200 baud rate using 8 data bits and one stop bit. Parity is not supported. Refer to Table 1.3 for Baud Rate switch configuration. Set S1 positions 6-7 for the desired Baud Rate configuration.

Table 1.3 Network Baud Rate setting

Baud Rate	S1-6	S1-7
1200	OPEN	OPEN
2400	CLOSED	OPEN
9600	OPEN	CLOSED
19200	CLOSED	CLOSED

- 1.4 Set 100-ohm termination resistor (if required). Network termination is required if the unit is located at the beginning or end of the network bus. Termination reduces unwanted reflections caused by data signal propagation due to long wire runs. Refer to Table 1.4 for switch configuration. Set S1 position 8 for network termination if required.

Table 1.4 Termination setting

Termination (100 ohms)	S1-8
Enabled	CLOSED
Disabled	OPEN

2.0 Messaging Format

- 2.1 The RS485 COMM utilizes the Edwards SigNet ASCII protocol for data messaging. Each unit is capable of consuming and/or producing messages from the master controller. SigNet message format is illustrated below.

<STX> <UA> <DDDD> <ZONE> <ETX> <CHKSUM>

- <STX> The <STX> character has a value of 2 hexadecimal and is required at the start of every message (1 byte).
- <UA> Two byte ASCII representation of the hex Unit. Example - If unit address 0A is chosen, the two byte <UA> data field would contain ASCII '0' and 'A' written in ASCII format as 0A. Valid data range is ASCII 00 - 1F.
- <DDDD> ASCII data field. (4 bytes total). These bytes contain commands, tone/message and timed sequence data.

<ZONE>	Programmable unit Zone issued by the master or controlling computer Range ASCII A-D (1 byte). Note – Zone value is not retained after power loss unless battery backup is installed. Value defaults to Zone A on power up.
<ETX>	The <ETX> character has a value of 3 hexadecimal and is required at the end of every message (1 byte)
<CHKSUM>	Optional two byte Message Block checksum (2 bytes). Refer to Section 4.0 for Block checksum calculation and verification. If checksum is not desired, must pad these two bytes with two ASCII zeros 00.

3.0 Message Command Set

3.1 Tone/Message Command - 00-1F

Send Format: <STX><UA><TONE> <TIME> <ZONE> <ETX> <CHKSUM>

<UA>	Unit address characters (2 bytes). See Section 2.0, Messaging Format
<TONE>	Tone/Message to be played by the unit. Example - If tone 06 is chosen, the two byte <TONE> data field should contain ASCII '0' and '6' written in ASCII format as 06. Range ASCII 00-1F(2 bytes). See Tone Chart for a list of available tones or messages.
<TIME>	Time sequence for Tone/Message to be played (00-99 seconds). For continuous play of Tone/Message, use '00' in this data field. Range ASCII 00-99 (2 bytes)
<ZONE>	Units matching this zone field will play Tone/Message indicated in the <TONE> data field for specified time indicated in <TIME> data field. All other zones remain in standby mode.
<ETX>	The <ETX> character has a value of 3 hexadecimal and is required at the end of every message (1 byte)
<CHKSUM>	Optional two byte Message Block checksum (2 bytes). Refer to Section 4.0 for Block checksum calculation and verification. If checksum is not desired, must pad these two bytes with two ASCII zeros 00.

3.2 BROADCAST COMMAND - 41

Send Format: <STX> 41 <TONE> <TIME> <ZONE> <ETX> <CHKSUM>

<41>	In this command type, two byte ASCII '41' replaces <UA> characters. This command is issued to all units containing the identical <ZONE> field.
<TONE>	Tone/Message to be played by the unit. See tone chart for a list of available tones/messages. Range ASCII 00-1F (2 bytes).
<TIME>	Time sequence for Tone/Message (00-99 seconds). For continuous play of Tone/Message, use '00' in this data field. Range ASCII 00-99 (2 bytes)
<ZONE>	Units matching this zone field will play Tone/Message indicated in the <TONE> data field for specified time indicated in <TIME> data field. All other zones remain in standby mode.
<ETX>	The <ETX> character has a value of 3 hexadecimal and is required at the end of every message (1 byte)
<CHKSUM>	Optional two byte Message Block checksum (2 bytes). Refer to Section 4.0 for Block checksum calculation and verification. If checksum is not desired, must pad these two bytes with two ASCII zeros 00.

Unit Response: None

Example: <STX>410530B<ETX>00

Units programmed with Zone 'B' only to play Tone 05 for 30 seconds then shut off automatically. Checksum characters not used in this example.

Note: do not use spaces between message characters in the above example.

3.3 POLL COMMAND and SET UNIT ZONE - 43

Send Format: <STX><UA>43<00><ZONE><ETX><CHKSUM>

<UA>	Unit address, ASCII Range 00-1F (two bytes)
<43>	Two byte ASCII Command denoting POLL Command or Zone Assignment (2 byte).

<00>	Two byte ASCII '00' used as protocol padding (two bytes)
<ZONE>	Programmable unit zone character. Range ASCII A-D. (1byte)
<ETX>	The <ETX> character has a value of 3 hexadecimal and is required at the end of every message (1 byte)
<CHKSUM>	Optional two byte Message Block checksum (2 bytes). Refer to Section 4.0 for Block checksum calculation and verification. If checksum is not desired, must pad these two bytes with two ASCII zeros 00.

Unit Response: <STX><UA>43<STATUS><ZONE><ACK><ETX><CHKSUM>

<UA>	Unit address, ASCII Range 00-1F (two bytes)
<43>	Two byte ASCII Command echoed back from receiving unit (2 byte).
<STATUS>	Unit's current diagnostic state. Range ASCII A - D. (1byte) A = Tone/Message is active and Local Power is absent B = Tone/Message is active and Local Power is present C = Tone/Message is not active and Local Power is absent D = Tone/Message is not active and Local Power is present
<ZONE>	Unit's programmed zone character
<ACK>	This <ACK> character has a value of 6 hexadecimal and represents acknowledgement of the received command with valid checksum (1byte).

Note: In the event that a bad checksum is calculated, by the receiving unit, it will reply with a <NAK> character instead. The <NAK> character has a value of 15 hexadecimal.

<ETX>	The <ETX> character has a value of 3 hexadecimal and is required at the end of every message (1 byte)
<CHKSUM>	Receiving unit calculates two-byte checksum and returns ASCII value. Refer to Section 4.0 for Block checksum calculation and verification.

Example 1: <STX>014300A<ETX>00

Unit 01 is being polled and programmed to Zone A

Unit Response: <STX>0143DA<ACK><ETX>56

The unit returned a <STATUS> 'D' for its current diagnostic state and an <ACK> character because both message and checksum are valid. The unit is not actively playing Tone/Message. The calculated two-byte message checksum was '56'.

Example 2: <STX>014300A<ETX>00

Unit 01 is being polled and programmed to Zone A. Unit 01 is currently playing a Tone/Message.

Unit Response: <STX>0143BA<ACK><ETX>54

The unit returned a <STATUS> 'B' for its current diagnostic state and an <ACK> character. The unit is actively playing a Tone/Message at the time this command was received. The calculated two-byte message checksum was '54'.

3.4 TIME SEQUENCE, TIME REMAINING COMMAND - 44

Send Format: <STX><UA>44 00 <ZONE> <ETX> <CHKSUM>

<UA>	Unit address characters (2 bytes). See Section 2.0, Messaging Format
<44>	Two byte ASCII Command denoting a Time Sequence (2 bytes).
<00>	Two byte ASCII '00' used as protocol padding (two bytes)
<ZONE>	Programmable unit Zone issued by the master or controlling computer Range ASCII A-D (1 byte).
<ETX>	The <ETX> character has a value of 3 hexadecimal and is required at the end of every message (1 byte)

<CHKSUM> Optional two byte Message Block checksum (2 bytes). Refer to Section 4.0 for Block checksum calculation and verification. If checksum is not desired, must pad these two bytes with two ASCII zeros 00.

Unit Response: <STX><UA> 44 <TIME LEFT><ACK><ETX> <CHKSUM>

<UA> Unit address characters (2 bytes). See Section 2.0, Messaging Format

<44> Two byte ASCII Command 43 echoed back from the receiving unit (2 bytes).

<TIME LEFT> Represents seconds left, in hexadecimal format, until the unit stops playing active Tone/Message. Range 00-63 hex (2 bytes). The unit's internal counter returns the time remaining in seconds represented by a two byte hexadecimal value in the above data field.

Note: For non-timed events, the unit returns two ASCII zeros '00'.

<ACK> Unit received a complete message and checksum characters are valid.

Note: In the event that a bad checksum is calculated, by the receiving unit, it will reply with a <NAK> character instead. The <NAK> character has a value of 15 hexadecimal.

<ETX> The <ETX> character has a value of 3 hexadecimal and is required at the end of every message (1 byte)

<CHKSUM> Receiving unit calculates two-byte checksum and returns ASCII value. Refer to Section 4.0 for Block checksum calculation and verification.

Example 1: Prior to issuing Command 44, the master issues a 99 second timed sequence event for Tone/Message 03 to play on unit address 1F.

Command: <STX>1F0399A<ETX>00

9 seconds after issuing command from above, the master issues the "Time Remaining" Command 44

Command: <STX>1F4400A<ETX>00 and the unit replies with the following message.

Reply: <STX>1F445A<ACK><ETX>5E

Value 5A (90 decimal) is the hexadecimal representation of seconds left before the timed sequence event completes and Tone/Message stops.

3.5 DEVICE TYPE COMMAND - 45

Send Format: <STX><UA>45<00> <ZONE> <ETX> <CHKSUM>

<UA> Unit address characters (2 bytes). See Section 2.0, Messaging Format

<45> Two byte ASCII Command 45 denoting receiving unit's Device type (2 bytes).

<00> Two byte ASCII '00' used as protocol padding (two bytes)

<ZONE> Programmable unit Zone issued by the master or controlling computer Range ASCII A-D (1 byte).

<ETX> The <ETX> character has a value of 3 hexadecimal and is required at the end of every message (1 byte)

<CHKSUM> Optional two byte Message Block checksum (2 bytes). Refer to Section 4.0 for Block checksum calculation and verification. If checksum is not desired, must pad these two bytes with two ASCII zeros 00.

Unit Response: <STX> <UA> <DEVICE TYPE> <vXX> <ETX> <CHKSUM>

<UA> Unit address characters (2 bytes). See Section 2.0, Messaging Format

<45> Two byte ASCII Command 45 echoed back from the receiving unit (2 bytes).

<DEVICE TYPE> Device type is an ASCII string transmitted by the receiving unit that defines the unit family product code. For Millennium devices, the return ASCII string is "M-485". For Edward's Visual devices, the return ASCII string is "S-485".

<vXX> Receiving Unit's Firmware version and revision level.

<ETX> The <ETX> character has a value of 3 hexadecimal and is required at the end of every message (1 byte).

<CHKSUM> Receiving unit calculates two-byte checksum and returns ASCII value. Refer to Section 4.0 for Block checksum calculation and verification.

Example: **Command:** <STX>014500A<ETX>00

Response: <STX>01M-485v1.0<ETX>84

Unit address 01 returns "M-485" string and is configured with version 1, rev.0 firmware. Calculated two-byte checksum is '84'.

3.6 RELAY ENERGIZE COMMAND - 31

Send Format: <STX><UA>31<TIME> <ZONE> <ETX> <CHKSUM>

<UA> Unit address characters (2 bytes). See Section 2.0, Messaging Format

<31> ASCII Command 31 denoting Relay Energize (2 bytes).

<TIME> Time sequence for relay 'ON' duration (00-99 seconds). For Continuous 'ON', use ASCII '00' in this data field. Range ASCII 00-99 (2 bytes)

<ZONE> Programmable unit Zone issued by the master or controlling computer Range ASCII A-D (1 byte).

<ETX> The <ETX> character has a value of 3 hexadecimal and is required at the end of every message (1 byte)

<CHKSUM> Optional two byte Message Block checksum (2 bytes). Refer to Section 4.0 for Block checksum calculation and verification. If checksum is not desired, must pad these two bytes with two ASCII zeros 00.

Response: <STX><UA>31<TIME> <ACK> <ETX> <CHKSUM>

Example: <STX>1F3105<ACK><ETX>00

Unit address 1F energizes relay for 5 seconds then shut off automatically. Checksum characters not used in this example.

<UA> Unit address

<31> Two byte ASCII Command 31 echoed back from receiving unit.

<TIME> Received two byte ASCII time value

<ACK> Unit received valid message and checksum

<ETX> The <ETX> character has a value of 3 hexadecimal and is required at the end of every message (1 byte).

<CHKSUM> Receiving unit calculates two-byte checksum and returns ASCII value. Refer to Section 5.0 for Block checksum calculation and verification.

Note: Relay output commands are only valid when there is no tone/voice message actively playing. Any tone/voice messages automatically overrides any relay output commands sent to the unit.

3.7 RELAY DE-ENERGIZE COMMAND - 30

Send Format: <STX><UA>30<00> <ZONE> <ETX> <CHKSUM>

<UA> Unit address characters (2 bytes). See Section 2.0, Messaging Format

<30> ASCII Command 30 denoting Relay De-Energize (2 bytes).

<00> Two byte ASCII '00' used as protocol padding (two bytes)

<ZONE> Assigned unit Zone. Range ASCII A-D (1 byte)

<ETX> The <ETX> character has a value of 3 hexadecimal and is required at the end of every message (1 byte).

<CHKSUM> Receiving unit calculates two-byte checksum and returns ASCII value. Refer to Section 4.0 for Block checksum calculation and verification.

Response: <STX><UA>3000 <ACK> <ETX> <CHKSUM>

Example: <STX>1F3000<ACK><ETX>43

Unit address 1F de-energizes relay output

<UA> Unit address

<30>	Two byte ASCII Command 30 echoed back from receiving unit.
<00>	Two byte ASCII '00' used as protocol padding (two bytes)
<ACK>	Unit received valid message and checksum
<ETX>	The <ETX> character has a value of 3 hexadecimal and is required at the end of every message (1 byte).
<CHKSUM>	Receiving unit calculates two-byte checksum and returns ASCII value. Refer to Section 4.0 for Block checksum calculation and verification.

4.0 Verify and Calculate Message Block Checksum

- 4.1 Message Block checksum can be verified by adding up all the hexadecimal characters in the received message string, excluding the first character <STX> and the very last two checksum characters.
- 4.2 The sum of these characters will produce a three-byte hexadecimal value. The higher order byte is not used and should be dropped. The lower two bytes are used for comparison to the received checksum characters. See example Message String received below:

Message String Received:

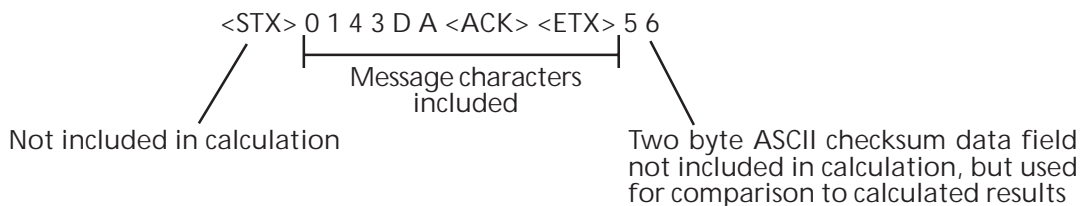

- 4.3 Calculating the checksum is done by first converting each ASCII character, found in the message string, to the hexadecimal equivalent and then summing these characters. See below.

ASCII	HEXADECIMAL
0	0x30
1	0x31
4	0x34
3	0x33
D	0x44
A	0x41
✓ (ACK)	0x06
┘ (ETX)	0x03
	0x156 hexadecimal total

- 4.4 Dropping the upper hexadecimal byte from the above total yields a final result of **56** hexadecimal. The calculated hexadecimal checksum value should match the ASCII value received in the message string. If it does not match, a possible error occurred during transmission and the message is considered unreliable. The master or controlling computer should try to resend the message again.

Example of a *POLL Command 43* issued to unit 05, Zone B

<STX>054300B<ETX>

ASCII	HEXADECIMAL
0	0x30
5	0x35
4	0x34
3	0x33
0	0x30
0	0x30
B	0x42
┘ (ETX)	0x03
	0x171 hexadecimal total

The calculated Message Block checksum are appended to the message string. Two bytes, ASCII 7 and ASCII 1, consume these two checksum data fields. See below.

Send format: <STX>054300A<ETX>**71**

5.0 Wiring applications

RS-232 to RS-485 Multi or Single drop

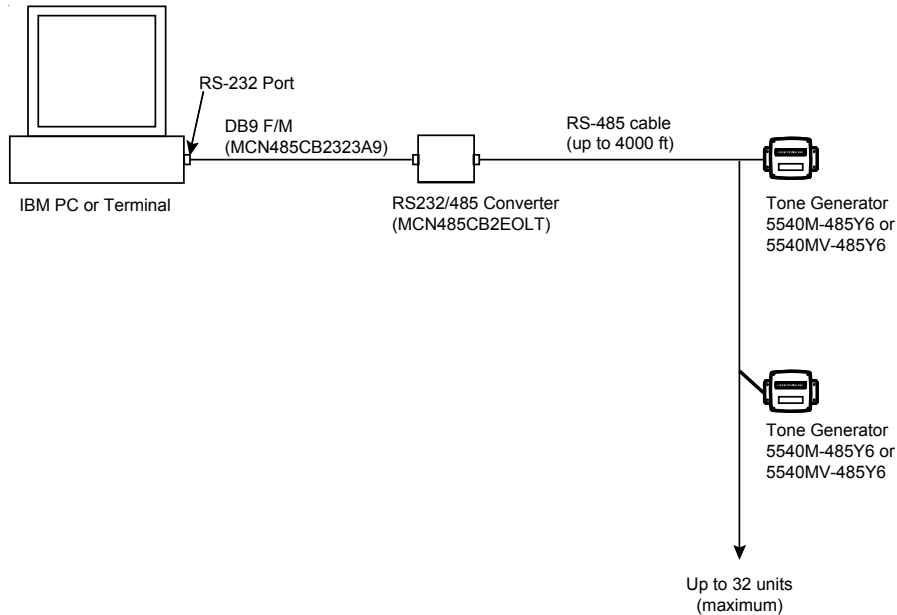

PLC to RS-485 Multi or Single drop

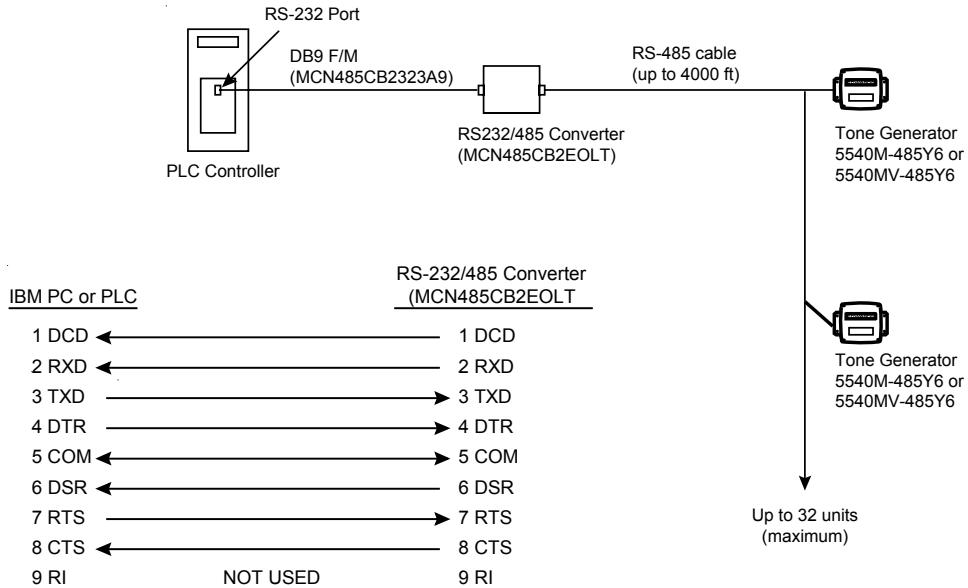

RS-485 Multi or Point to Point

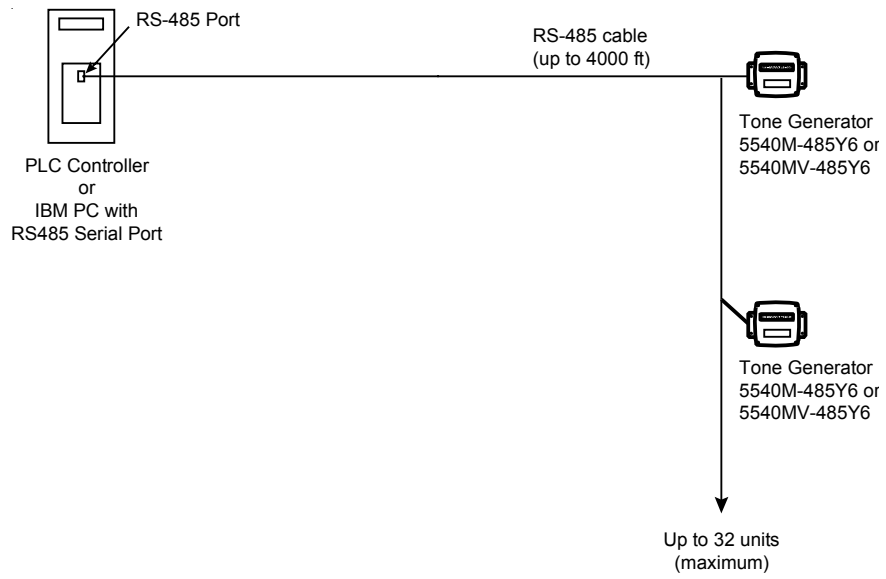

Suggested Network Topology Node Schemes

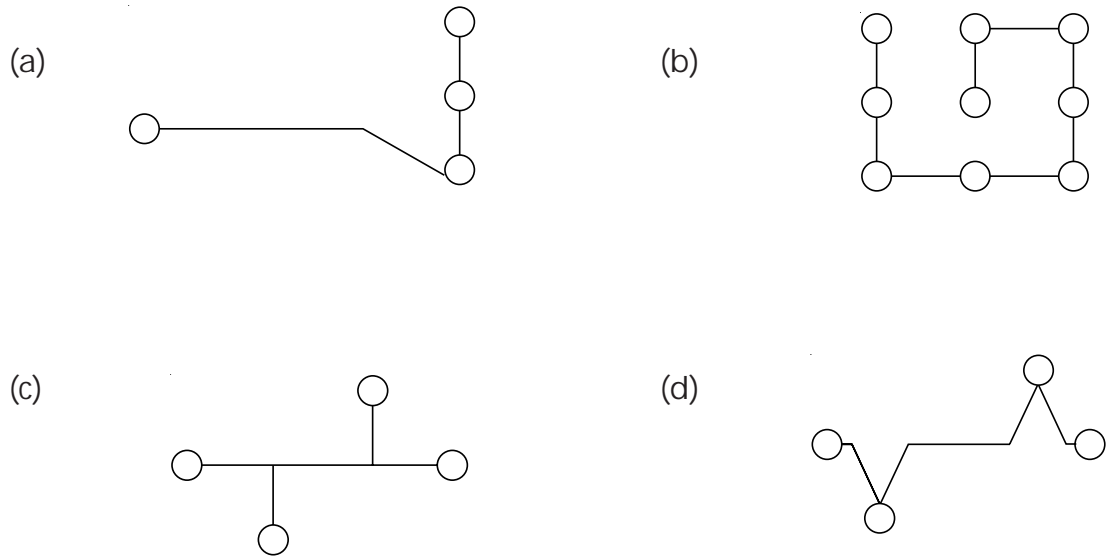

Wiring to RS-232/485 Convert Box (MCN485CB2EOLT)

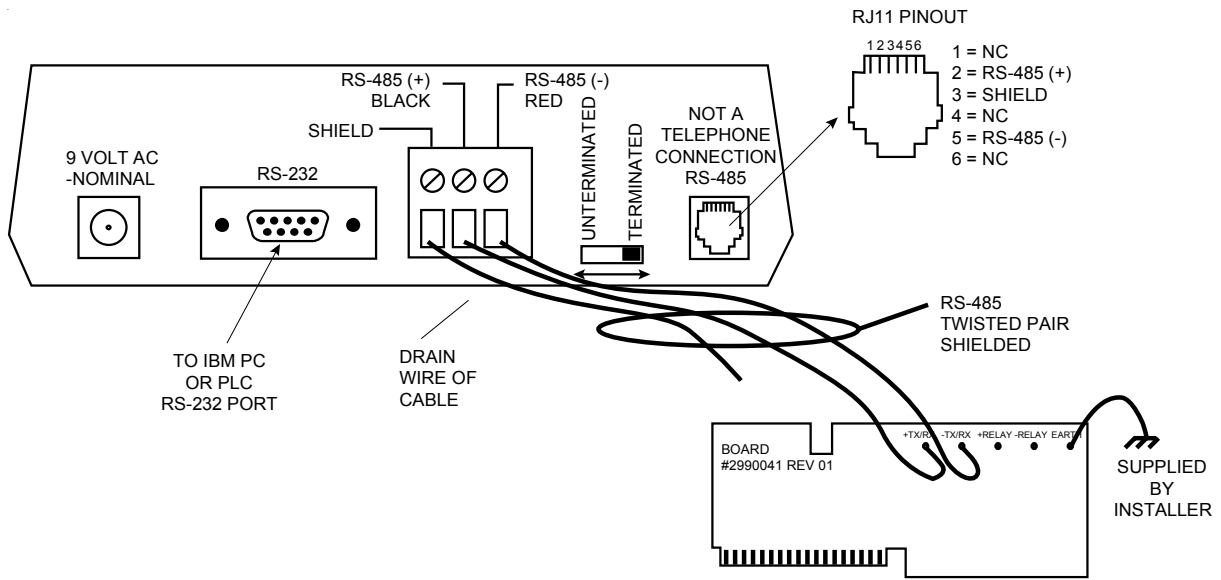

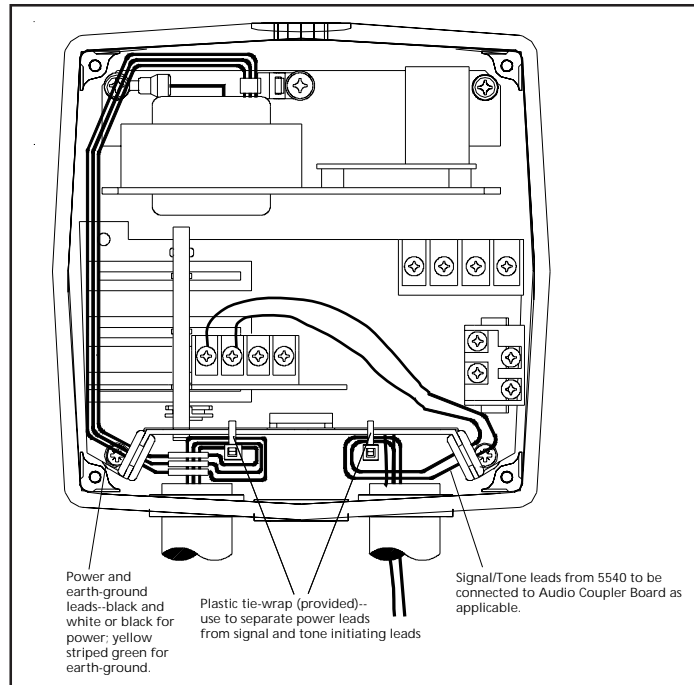

Figure 4. Wiring the 5532M Series Speaker/Amplifier

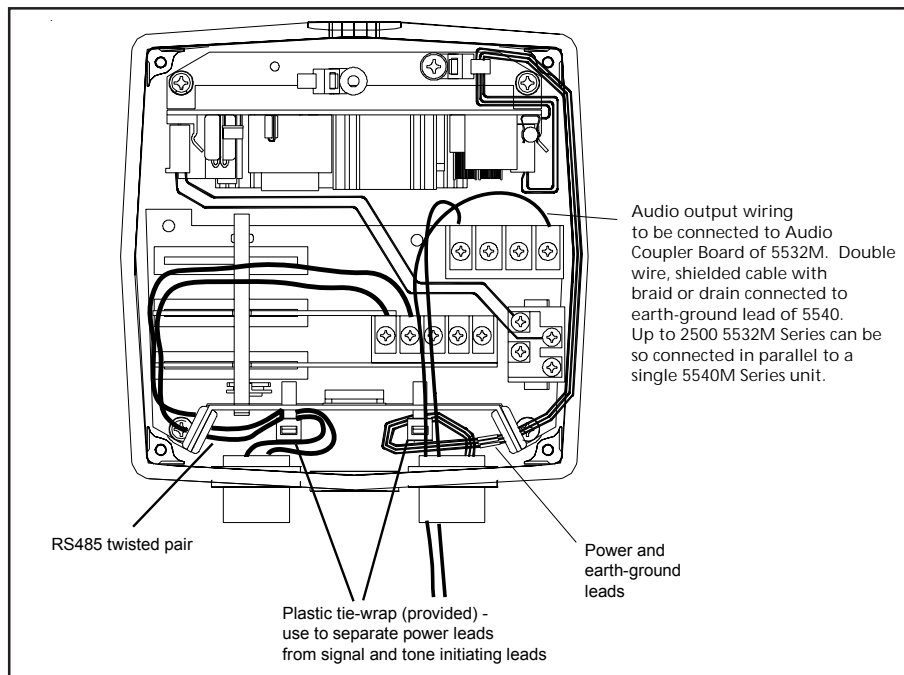

Figure 5. Wiring the 5540MV Series Tone Generator with Voice Messaging

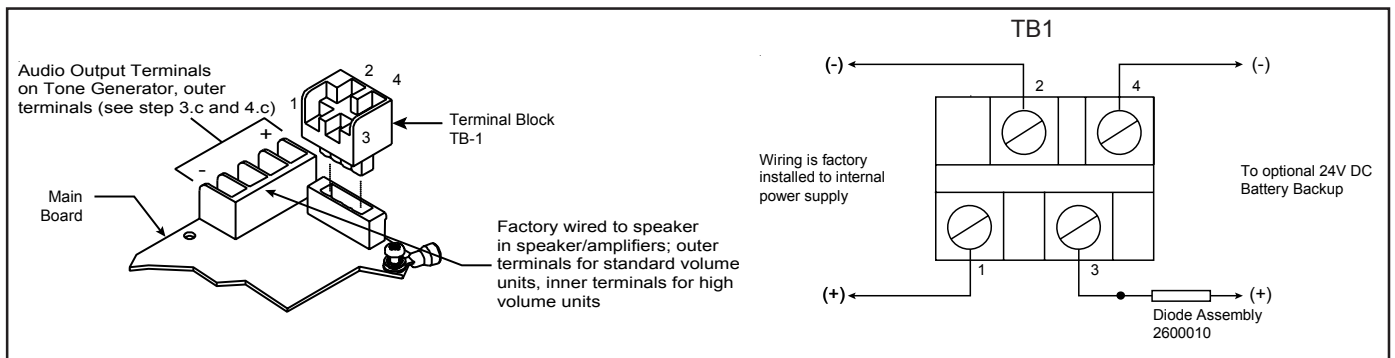

Figure 6. Wiring to Tone Generator Terminal Blocks

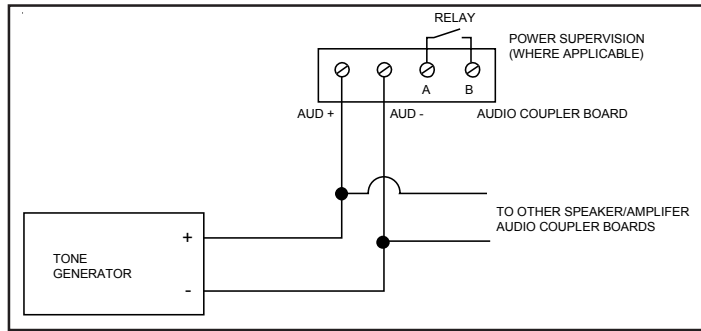

Figure 7. Wiring Audio Output of Tone Generator to Speaker/Amplifier Audio Coupler Board

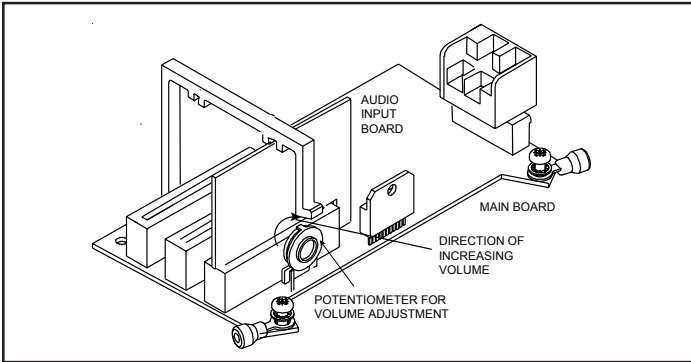

Figure 8. 5532M Series PC Board Locations

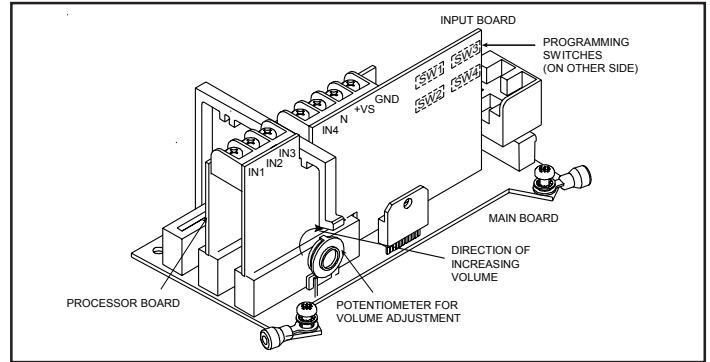

Figure 9. 5540M Series PC Board Locations

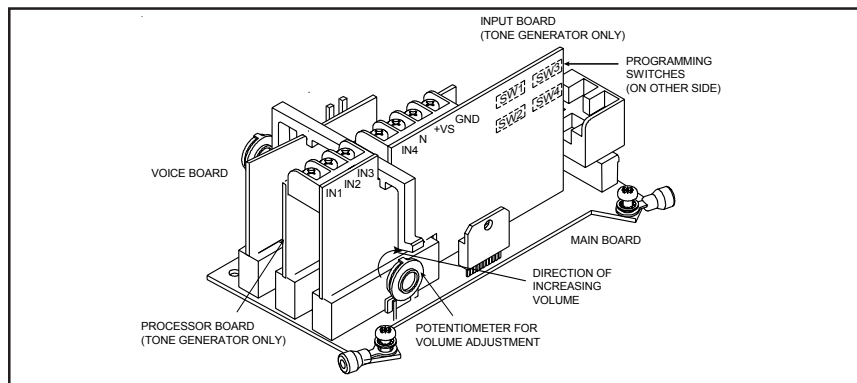

Figure 10. 5540MV Series PC Board Locations

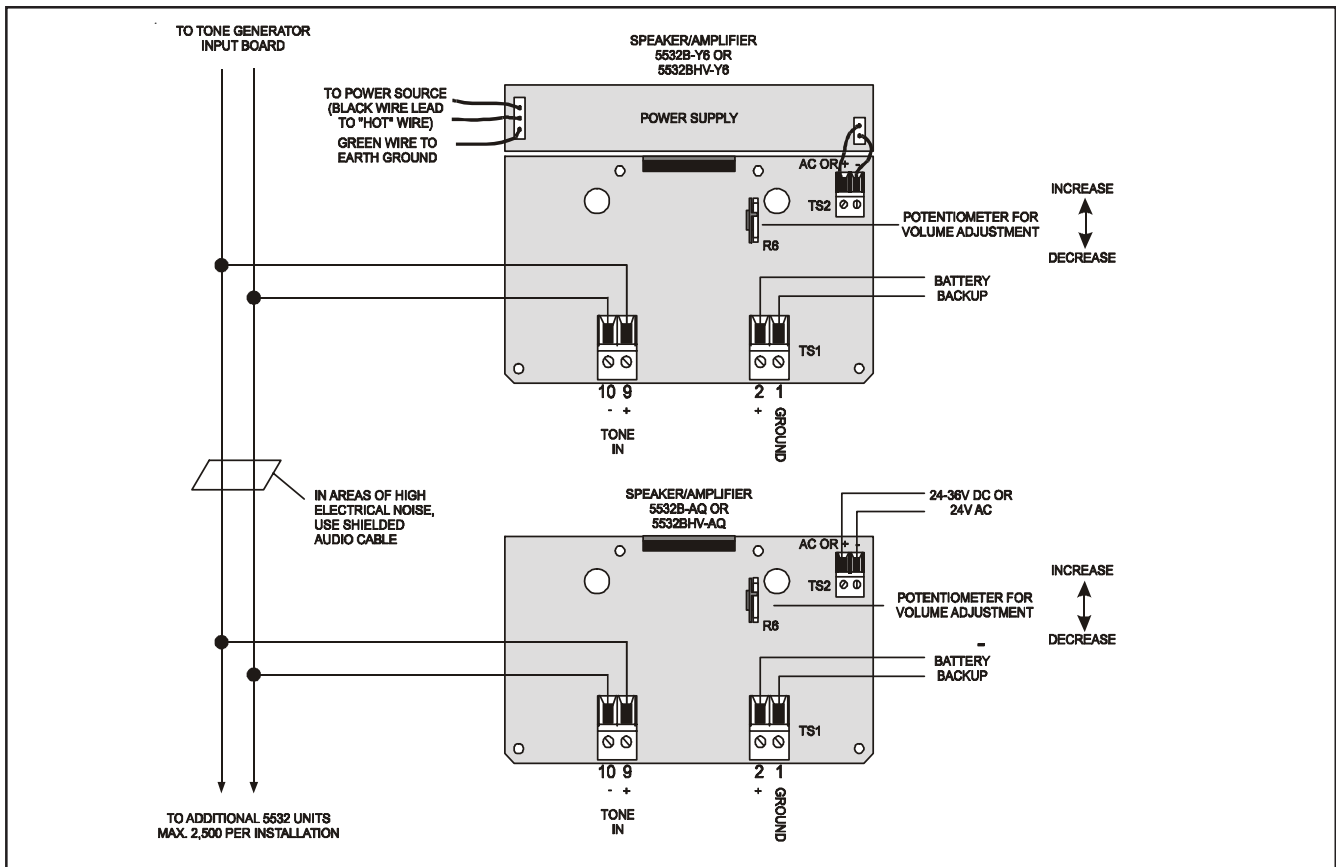

Figure 11. Connecting to the 5532B Series Speaker/Amplifiers

Figure 12. Tone Programming

Tone	Description	Switch					HEX
		1	2	3	4	5	
No Tone		○	○	○	○	○	00
Ding-Dong	Percussive pairs of 700 and 570 Hz tones, each damped to zero	●	○	○	○	○	01
Warble	575 and 770 Hz alternately, 87 ms each	○	●	○	○	○	02
Siren	600-1250 Hz up and down sweep in 8 seconds and repeat	●	●	○	○	○	03
Stutter	Percussive 470 Hz, 83 ms on, 109 ms off	○	○	●	○	○	04
Slow Whoop	600-1250 Hz upward sweep in 4 seconds and repeat	●	○	●	○	○	05
Beep	470 Hz, 0.55 seconds on, 0.55 seconds off	○	●	●	○	○	06
Chime 1	700 Hz percussive repeat at 1 Hz	●	●	●	○	○	07
Fast Whoop	600-1250 Hz upward sweep in 1 second and repeat	○	○	○	●	○	08
Hi/Lo	780 to 600 Hz alternately, 0.52 seconds each	●	○	○	●	○	09
Rapid Siren	600-1250 Hz up and down sweep in 0.25 seconds and repeat	○	●	○	●	○	0A
Yeow	1250-600 Hz downward sweep in 1.6 seconds and repeat	●	●	○	●	○	0B
Horn	470 Hz continuous	○	○	●	●	○	0C
Air Horn	370 Hz continuous	●	○	●	●	○	0D
Dual Tone	450-500 Hz, 0.4 to 0.5 second cycle	○	●	●	●	○	0E
Chime 2	575 Hz percussive repeat at 1 Hz	●	●	●	●	○	0F
Westminster	Two measures, 411 Hz, 520 Hz, 407 Hz, 312 Hz	○	○	○	○	●	10
Three Blind Mice	Four measures, 787 Hz, 714 Hz, 625 Hz, 952 Hz, 333 Hz	●	○	○	○	●	11
Phasor	416-625 Hz up and down sweep in 13 ms and repeat	○	●	○	○	●	12
Telephone	570 and 770 Hz alternately, 50 ms each for 1.2s, 1.5s delay and repeat	●	●	○	○	●	13
Staircase	440-2000 Hz up and down steps, 750 ms delay and repeat	○	○	●	○	●	14
3 Tone Alert	463, 641 and 896 Hz, 200 ms each, 1 second delay and repeat	●	○	●	○	●	15
Presignal Chime	470 Hz percussive repeat at 1.5 Hz, followed by Message 1	○	●	●	○	●	16
Message 1	Field recorded voice message	●	●	●	○	●	17
Message 2	Field recorded voice message	○	○	○	●	●	18
Message 3	Field recorded voice message	●	○	○	●	●	19
Message 4	Field recorded voice message	○	●	○	●	●	1A
NFPA Whoop	Three 422-775 Hz upward sweeps, 850 ms each, 1s delay and repeat	●	●	○	●	●	1B
3 Pulse Horn	470 Hz, 3 0.5 second pulses separated by 0.5 seconds followed by a 1.5 second delay and repeat-- For Evacuation Use Only	○	○	●	●	●	1C
3 Pulse Air Horn	370 Hz, 3 0.5 second pulses separated by 0.5 seconds followed by a 1.5 second delay and repeat-- For Evacuation Use Only	●	○	●	●	●	1D
3 Pulse Dual Tone	450-500 Hz, 0.4 to 0.5 second cycle, 3 0.5 second pulses separated by 0.5 seconds followed by a 1.5 second delay and repeat-- For Evacuation Use Only	○	●	●	●	●	1E
3 Pulse Chime 2	575 Hz, 3 0.5 second pulses separated by 0.5 seconds followed by a 1.5 second delay and repeat-- For Evacuation Use Only	●	●	●	●	●	1F



CAUTION

The use of evacuation signals on this product, that is not specifically Listed for Fire Alarm Use, is subject to the approval of the Authority Having Jurisdiction.

EDWARDS SIGNALING

Installation Instructions for Adaptatone Millennium Tone Generator Series 5540M-24, 5540M-120 and Tone Generator with Voice Messaging Series 5540MV-24 and Speaker/Amplifier, Series 5532

Description and Operation

Edwards Tone Generator and Speaker/Amplifiers are intended for industrial applications where high audible output and microcomputer reliability are required. Catalog Series 5540M and 5532M ending with suffixes -AQ, -24AQ, -Y6 or -24Y6 are CE Marked and TÜV-RHEINLAND Certified for compliance to the European Union's Electromagnetic Compatibility (Industrial) and Low Voltage Safety Directives (see Declaration of Conformity, available upon request). Additionally, the Adaptatone Millennium series are UL and cUL Listed as Audible Signal Appliances for use in the following hazardous locations.

Catalog Number	Hazardous Locations	Temp. Code
5532M-AQ 5532M-N5 5532M-Y6 5532MHV-AQ 5532MHV-Y6	Class I, Div. 2, Groups A, B, C, D Class II, Div. 2, Groups F, G Class III, Div. 1 and 2	T4 (135C) T5 (100C)
5540M-24AQ 5540M-24N5 5540MV-24N5 5540M-120N5*	Class I, Div. 2, Groups A, B, C, D Class II, Div. 2, Groups F, G Class III, Div. 1 and 2	T4A (120C) T5 (100C)
5540M-24Y6 5540MV-24Y6 5540M-120Y6*	Class I, Div. 2, Groups A, B, C, D Class II, Div. 2, Groups F, G Class III, Div. 1 and 2	T4 (135C) T5 (100C)

*Catalog Numbers ending in -120N5 and -120Y6 are NOT cUL Listed.

The 5532B Speaker/Amplifiers are UL Listed and CSA Certified as Audible Signaling Appliances.

The Tone Generator operates from local power. It accommodates up to four normally-open contacts on its inputs. The tone that sounds in response to an active input is determined by setting miniature programming switches inside the unit. Figure 19 has switch settings for setting tones.

Four tones may be programmed into the Tone Generator at any time. These tones operate on a pyramid-type priority system. The tone programmed on SW1 overrides the tones programmed on SW2, SW3, and SW4. The tone on SW2 overrides the tones programmed on SW3 and SW4. Likewise, the tone on SW3 overrides the tone programmed on SW4. The tone programmed on SW4 has the lowest priority and cannot override any other programmed tone.

Speaker/Amplifiers are heavy-duty, stand-alone signaling devices that operate from local power and sound a tone programmed at the Tone Generator. Speaker direction and the output level are easily adjustable. Up to 2500 of these Speaker/Amplifiers can be connected in parallel to the tone output of a single tone generator.

Specifications

Weight - Tone Generator 6 Pounds (2.7 kg)
Weight - Speaker/Amplifier 9 Pounds (4.1 kg)

Hazardous Locations, UL Standard UL1604

Ambient Temp. +41F to +104F (+5C to +40C)

Non-Hazardous Locations

Variable Ambient Temp. -40F to +151F (-40C to +66C)

Hazardous Locations and Variable Ambient Conditions apply only where UL listings are accepted and do not apply to either CE conformity or TUV-Rheinland Certification.

Electrical Specifications

Catalog Number	Input Board		Main Power		
	Voltage	Current	Voltage	Current (A)	
				Standby	Tone On
Tone Generator					
5540M-24AQ	24V DC	6 mA	24V DC 24V AC 50/60 Hz	0.10 0.10	0.74 1.3
5540M-24N5 5540MV-24N5	24V DC	6 mA	120V AC 50/60 Hz	0.10	0.36
5540M-24Y6 5540MV-24Y6	24V DC	6 mA	125V DC** 250V DC** 120V AC 50/60 Hz 240V AC 50/60 Hz	0.10 0.02 0.10 0.10	0.21 0.10 0.32 0.20
5540M-120N5	120V AC 50/60 Hz	13 mA	120V AC 50/60 Hz	0.10	0.38
5540M-120Y6	120V AC 50/60 Hz	13 mA	125V DC** 250V DC** 120V AC 50/60 Hz 240V AC 50/60 Hz	0.10 0.02 0.10 0.10	0.20 0.10 0.31 0.20
Speaker/Amplifier - Standard Volume					
5532M-AQ			24V DC 24V AC 50/60 Hz	0.10 0.10	0.74 1.3
5532M-N5			120V AC 50/60 Hz	0.10	0.36
5532M-Y6			125V DC** 250V DC** 120V AC 50/60 Hz 240V AC 50/60 Hz	0.10 0.02 0.10 0.10	0.21 0.10 0.32 0.20
5532B-AQ			24V DC 36V DC 24V AC 60 Hz 24V AC 50 Hz	0.06 0.07 0.26 0.26	0.69 0.84 1.36 1.36
5532B-N5			120V AC 60 Hz 120V AC 50 Hz	0.10 0.09	0.29 0.29
5532B-Y6			125V DC** 250V DC** 120V AC 60 Hz 240V AC 60 Hz 120V AC 50 Hz 240V AC 50 Hz	0.05 0.04 0.10 0.11 0.09 0.10	0.16 0.10 0.29 0.23 0.29 0.22
Speaker/Amplifier - High Volume					
5532MHV-AQ			24V DC 24V AC 50/60 Hz	0.10 0.10	1.5 2.3
5532MHV-Y6			125V DC** 250V DC** 120V AC 50/60 Hz 240V AC 50/60 Hz	0.10 0.02 0.10 0.10	0.39 0.19 0.56 0.34
5532BHV-AQ			24V DC 36V DC 24V AC 60 Hz 24V AC 50 Hz	0.06 0.07 0.26 0.26	1.51 1.98 1.86 1.86
5532BHV-Y6			125V DC** 250V DC** 120V AC 60 Hz 240V AC 60 Hz 120V AC 50 Hz 240V AC 50 Hz	0.05 0.04 0.10 0.11 0.09 0.10	0.25 0.23 0.62 0.33 0.62 0.33

**CE mark and TÜV-Rheinland Certifications do not apply to 125V DC or 250V DC.

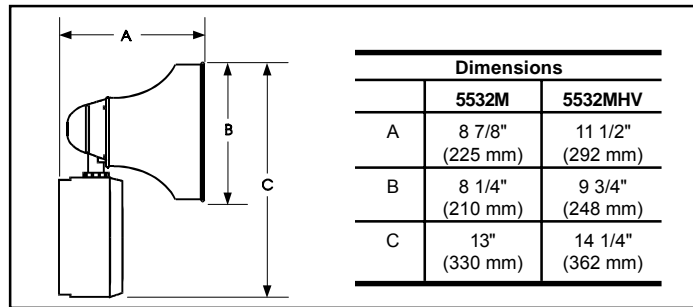

Figure 1. Speaker/Amplifier Dimensions

Table 1. Programming Logic Controller (PLC) Compatibility: PLC output to meet following product input parameters. See Figures 16 and 17

Cat. No.	Operating voltage (Volts*)	Max. off state leakage current (mA)	Continuous on current (mA)	Surge (inrush/duration) (Amps/milliseconds)
5540M-24AQ	24V DC only	2	740	8/4
5540M-24N5	120V 60 Hz	2	360	2.82/4
5540M-24Y6	120V 60 Hz	2	320	2.82/4
5540M-120N5	120V 60 Hz	5	380	2.82/4
5540M-120Y6	120V 60 Hz	5	310	2.82/4
5540MV-24N5	120V 60 Hz	2	360	2.82/4
5540MV-24Y6	120V 60 Hz	2	320	2.82/4
Input Board Circuit	24V DC	2	6	--
Input Board Circuit	120V 60 Hz	5	13	--

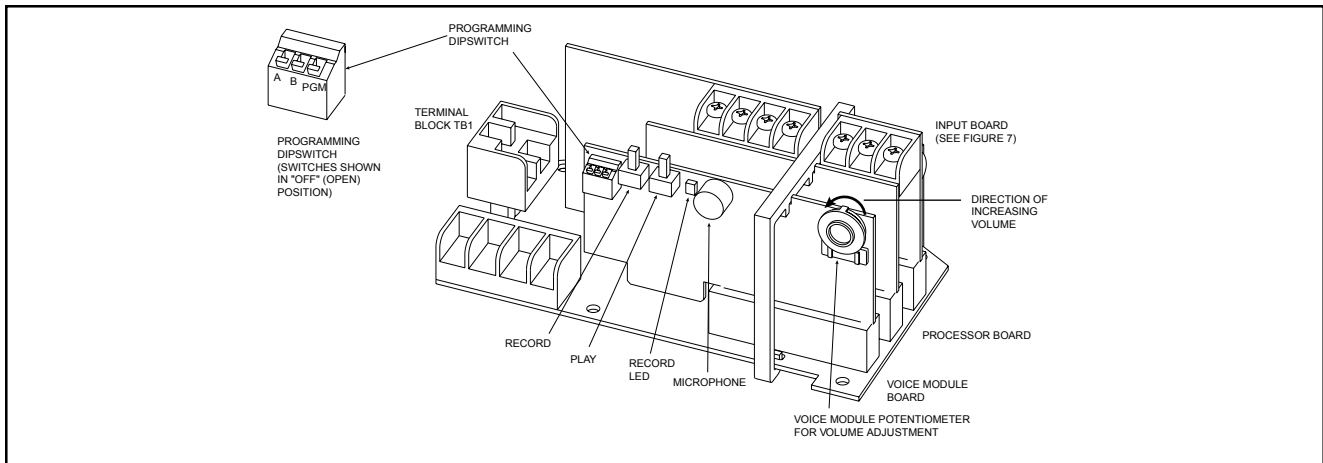

Figure 2. Voice Module Board

Recording a Voice Message (5540MV-24N5 and 5540MV-24Y6)



WARNING

High voltage is present when product is energized.

Four five-second messages (or one twenty-second message) can be recorded on the voice module unit. Refer to Figure 2.

1. Put switches A and B on the programming dipswitch in the proper position for the message to be recorded

Message Location	Start	Switch Settings	
		A	B
1	0 Sec.	CLOSED	CLOSED
2	5 Sec.	OPEN	CLOSED
3	10 Sec.	CLOSED	OPEN
4	15 Sec.	OPEN	OPEN

(Figure 2). For programming a message longer than five seconds, use Message Location 1.

2. Put switch PGM on the programming dipswitch in the "CLOSED" position for programming mode (Figure 2).
3. Press and hold the record button while speaking clearly into the microphone to record your message. Release the button when recording is complete.
4. To test the message, press and hold PLAY while in programming mode.

NOTE: This will play only the current location.



WARNING

High volume may cause harm to personnel in close proximity.

5. Adjust the volume as necessary. Set the main volume using the potentiometer on the main board (Figures 13, 14 and 15) and then set the voice volume using the potentiometer on the voice module board (Figure 2).

Installation

The Adaptatone may be mounted to any flat surface or may be used as a freestanding unit mounted to a rigid pipe. The Adaptatone must be installed in accordance with the latest edition of the National Electrical Code or other regulations applicable to the country and locality of installation and by a trained and qualified electrician.

NOTE: *The increased resistance due to long wire runs needs to be accounted for in sizing wire. Consult Applications Engineering for details.*

For catalog numbers ending in "AQ," 24V AC power must be transformer isolated from mains or line power.



CAUTION

During installation, care must be taken so that components on the printed circuit board are not damaged.

1. Mount Adaptatone as shown in Figure 3.

- a. **Flat Surface Mounting.** Secure unit to mounting surface using the (4) mounting holes in the mounting plate on the rear of the box. Use the #10 x 3" (76 mm) wood screws (furnished loose) or other hardware (not supplied) suitable for the mounting surface.
- b. **Rigid Pipe Mounting.** Loosen the (4) cover screws from the signal box and lift off signal box cover.

NOTE: *Cover screws are captive. Do not remove from cover.*

Remove the center knockout in lower wall of box and mount box to a 1/2" (12.7 mm) conduit pipe using suitable connector.

2. Install wires through a knockout hole in the bottom of the box from a raceway that is, with its connections to the 1/2" (12.7 mm) conduit knockout hole, approved for the same degree of protection and enclosure type needed by the application. Use the provided plastic tie-wrap, on the barrier to the electronics, to separate incoming power leads from signal and tone initiating leads, per NEC (Figures 4, 5 and 6).

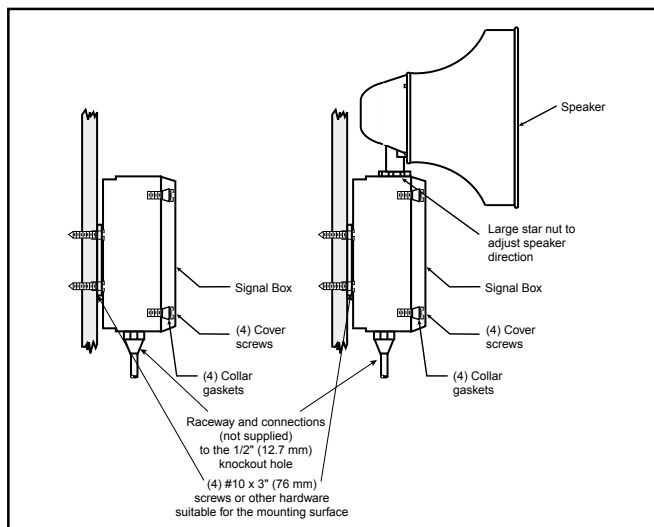

Figure 3. Adaptatone Mounting



WARNING

To prevent fire and shock, wire the Adaptatone only as described in this installation instruction.

3. Wire as follows referring to Figures 4, 5, and 6 (These instructions apply to both tone generator and 5532M series speaker/amplifier, except as noted):

If Edwards Signal Actuator catalog number 5538-4 is used to manually initiate tones, connect its four normally-open switches to the Tone Generator as shown on instructions provided with the Signal Actuator unit.

- a. Connect green and yellow striped earth-ground wires to earth-ground and, additionally, on tone generator, to braid or drain of audio cable in step b.
- b. See Figures 7, 12, 13, 14 and 15. Connect audio output (+) from the main board of the tone generator to the AUD (+) terminal on the Speaker/Amplifier Audio Coupler Board. Connect audio output (-) from the main board of the tone generator to the AUD (-) terminal on the Speaker/Amplifier Audio Coupler Board. Use shielded cable and connect braid or drain to earth-ground wire lead of 5540 Tone Generator. Up to 2500 Speaker/Amplifiers can be so connected in parallel to a single tone generator.
- c. For the tone generator, select the appropriate method of wiring to the input board from Figures 8, 9, 10, 11, 16 or 17. Connect the tone generator as shown.
- d. Connect incoming power to wire leads using a butt splice or other method listed, certified, or otherwise approved by local authorities. Leads are both black for -AQ and -N5 models and are black for line and white for neutral for -Y6 models.
- e. Optional. Connect external 24V DC battery (not supplied) in series with separate diode assembly part 2600010 (supplied) to TB1 terminals 3 and 4 on the main board as shown in Figure 7 and marked on the diode assembly.

NOTE: *Terminal Block TB1 can be unplugged from the main board to complete wiring as shown in Figure 7.*

4. Wire to the 5532B series speaker/amplifier as follows and referring to Figures 5, 6, 7 and 18:

If Edwards Signal Actuator catalog number 5538-4 is used to manually initiate tones, connect its four normally-open switches to the Tone Generator as shown on instructions provided with the Signal Actuator unit.

- a. Connect green earth-ground wire of speaker/amplifier and green and yellow striped earth-ground wires on tone generator to earth-ground.
- b. Connect audio output (+) from the main board of the tone generator to the Tone In terminal 9 (+) in the Speaker/Amplifier. Connect audio output (-) from the main board of the tone generator to the Tone In Terminal 10 (-) in the Speaker/Amplifier. Up to 2500 Speaker/Amplifiers can be so connected in parallel to a single tone generator.

- c. For the tone generator, select the appropriate method of wiring to the input board from Figures 8, 9, 10, 11, 12, 16 or 17. Connect the tone generator as shown.
- d. For 5532B-AQ, 5532BDV2-AQ and 5532BHV-AQ models, connect power source to the Speaker/Amplifiers at TS2. Polarity must be observed for DC models.
- e. For 5532B-Y6, 5532BDV2-Y6, 5532BHV-Y6, and 5532B-N5 models, connect incoming power to wire leads from power supply. For -Y6 models using a DC source, black wire is positive and white is negative and polarity must be observed. For AC source, black is line and white is neutral.
- f. For tone generator, connect incoming power to wire leads using a butt splice or other method listed, certified, or otherwise approved by local authorities. Leads are both black for -AQ and -N5 models and are black for line and white for neutral for -Y6 models.
- g. Optional. Wire 24V DC battery backup to TS1-1 and TS1-2 of the Speaker/Amplifier per Figure 18 and connect 24V DC battery backup in series with diode assembly part 2600010 (supplied) to TB1 terminals 3 and 4 on the main board of the tone generator per Figure 7. Polarities must be observed.

NOTE: Terminal block TB1 can be unplugged from the main board of the tone generator to complete wiring.

- 5. Refer to Figures 14, 15 and 19 and select desired tones. On the tone generator, set miniature programming switches on the input board.

For input connected to IN1, set on SW1; IN2, set on SW2; IN3, set on SW3, and IN4, set on SW4, in order of priority desired.

! **WARNING**
 HIGH VOLTAGE is present when product is energized. High volume may cause harm to personnel in close proximity.

- 6. Adjust volume level, if desired, by turning potentiometer located on the main board (Figures 13, 14, 15 and 18) and on voice board (Figure 2).

! **WARNING**
 To ensure integrity of the Adaptatone assembly when adjusting the speaker direction, make sure threads in the enclosure remain fully engaged and do not turn speaker more than 360 degrees from the original factory installed position.

- 7. To adjust speaker direction, loosen large star nut (Figure 3) and turn speaker to the approximate desired position. Retighten nut and turn speaker slightly clockwise until locked into place.

! **WARNING**
 To ensure integrity of the enclosure: Ensure the cover gasket, part number P-007549-0069, is adhered into groove at cover perimeter before replacing the signal box cover.
 Ensure that the (4) collar gaskets, part number P-041930-0362, are in place on each cover screw before securing the signal box cover.
 When securing cover, start screws by hand, making sure they are threaded into tapped holes in housing bosses before securing with a screwdriver. Torque signal box cover screws to a minimum of 20 in-lbs. This ensures the required tight fit.

- 8. Tightly secure the signal box cover using (4) retained cover screws.
- 9. Torque signal box cover screws to a minimum of 20 in-lbs.
- 10. Verify operability.

Maintenance and Test

! **WARNING**
 Ensure that power is disconnected before cleaning inside of unit.

Examine the unit semi-annually for accumulation of dirt. Clean if necessary.

The Adaptatone should be tested annually or as required by the authority having jurisdiction to ensure continuous service.

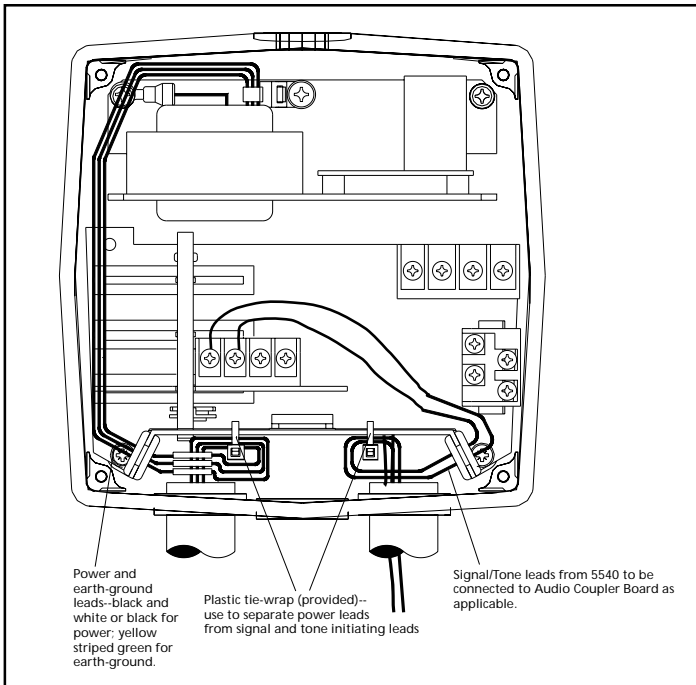

Figure 4. Wiring the 5532M Series Speaker/Amplifier

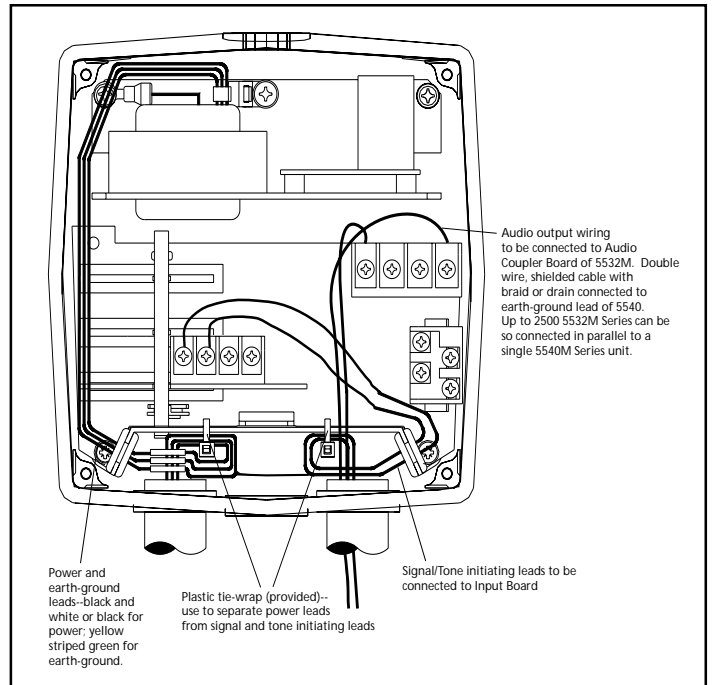

Figure 5. Wiring the 5540M Series Tone Generator

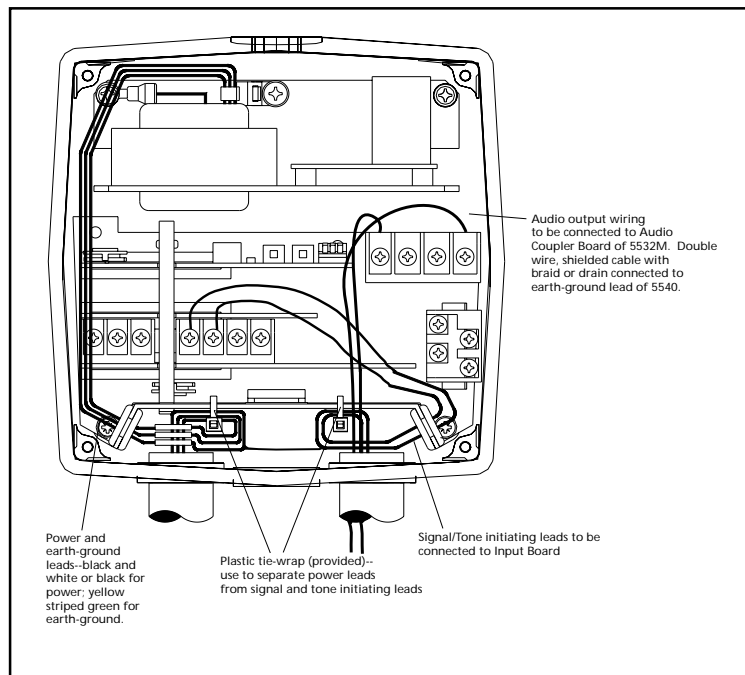

Figure 6. Wiring the 5540MV Series Tone Generator with Voice Messaging

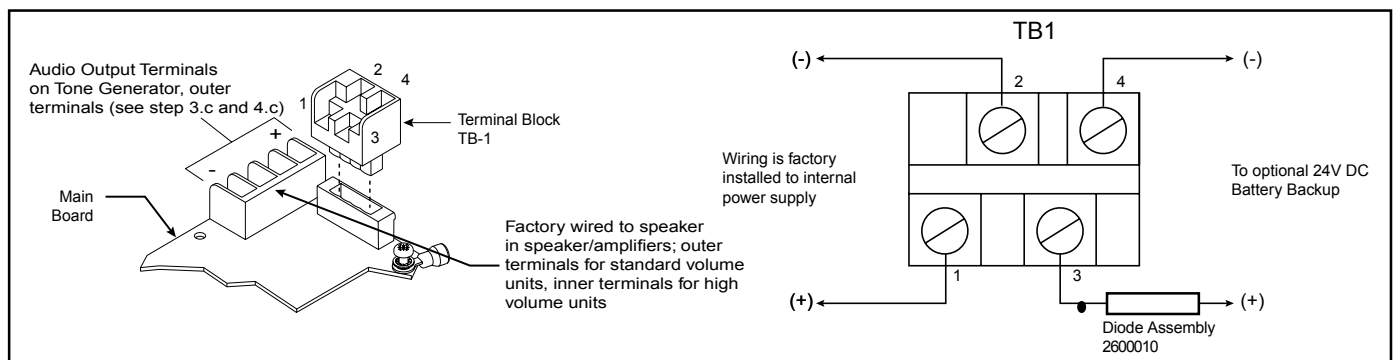

Figure 7. Wiring to Tone Generator Terminal Blocks

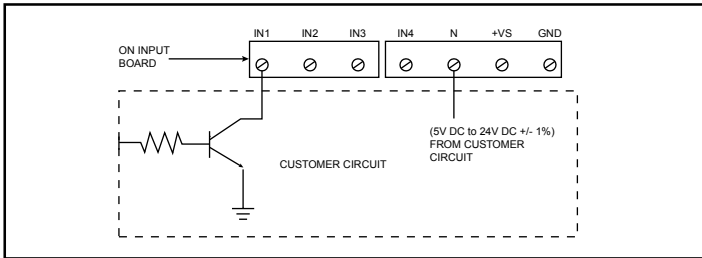

Figure 8. Wiring an Open Collector Transistor to Tone Generator Input Board

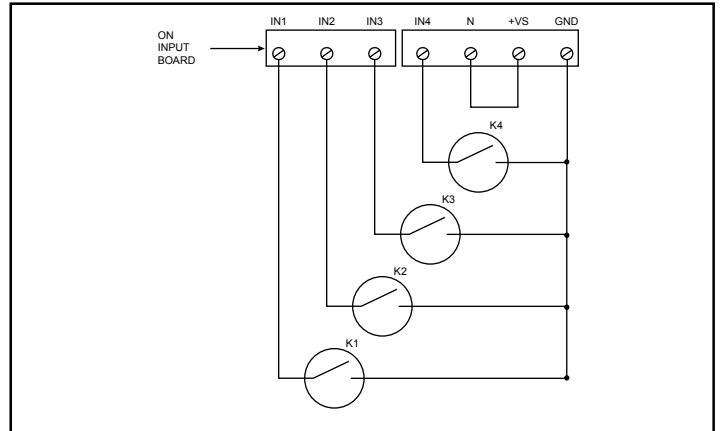

Figure 9. Wiring Multiple Dry Relay Contacts to 24V Tone Generator Input Board Method 1
(Refer to Applications Engineering for compatibility with earlier versions of Adaptatone)

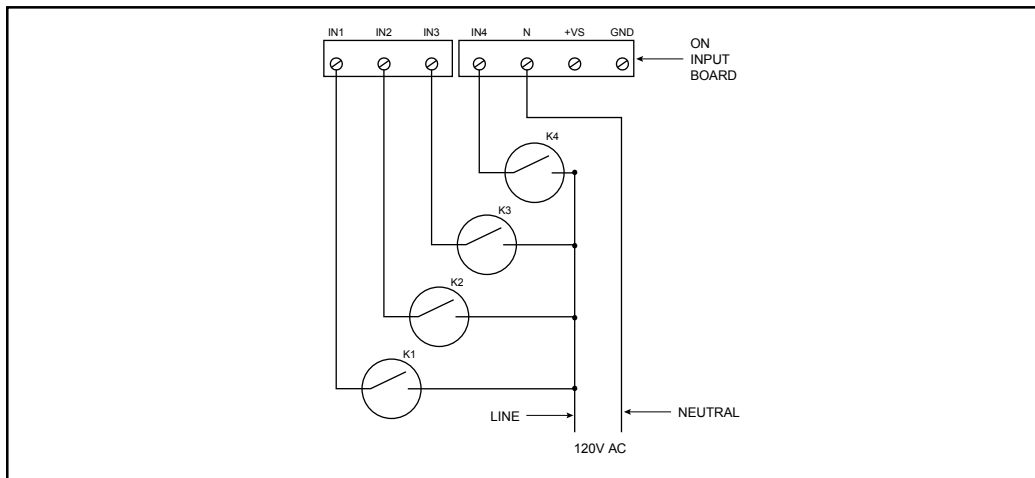

Figure 10. Wiring Multiple Dry Contacts to 120V Tone Generator Input Board

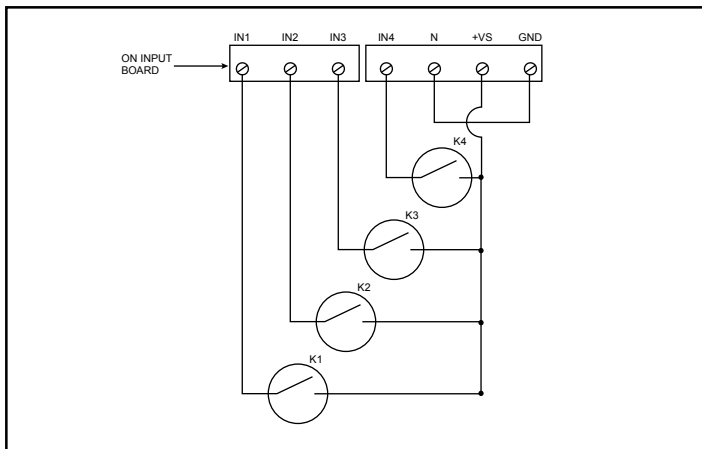

Figure 11. Wiring Multiple Dry Relay Contacts to 24V Tone Generator Input Board Method 2

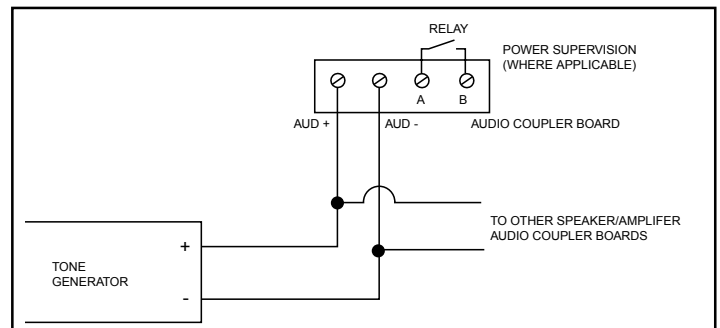

Figure 12. Wiring Audio Output of Tone Generator to Speaker/Amplifier Audio Coupler Board

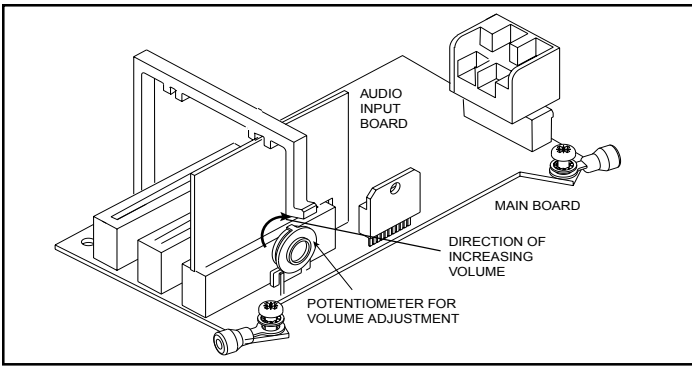

Figure 13. 5532M Series PC Board Locations

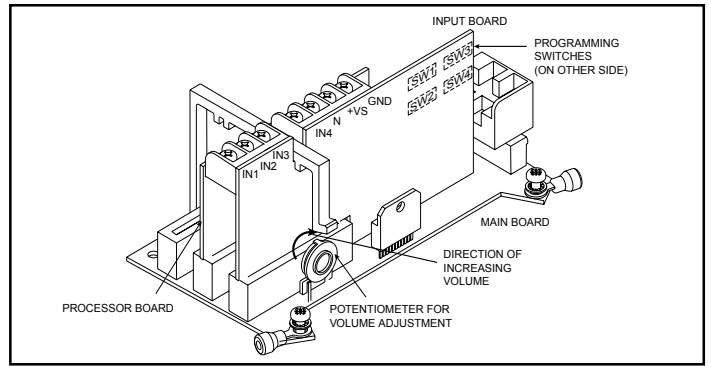

Figure 14. 5540M Series PC Board Locations

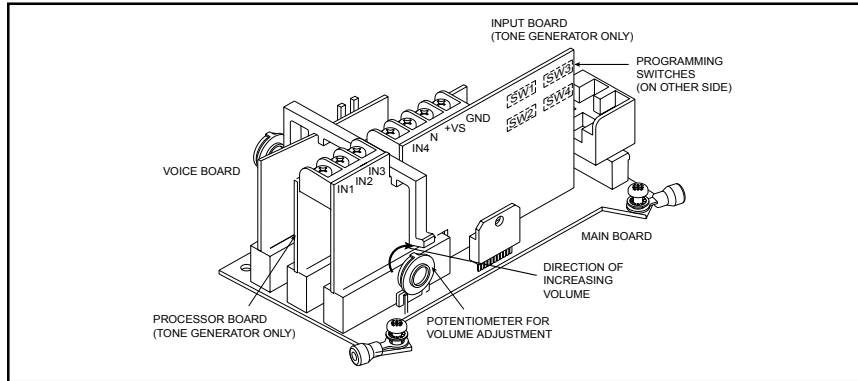

Figure 15. 5540MV Series PC Board Locations

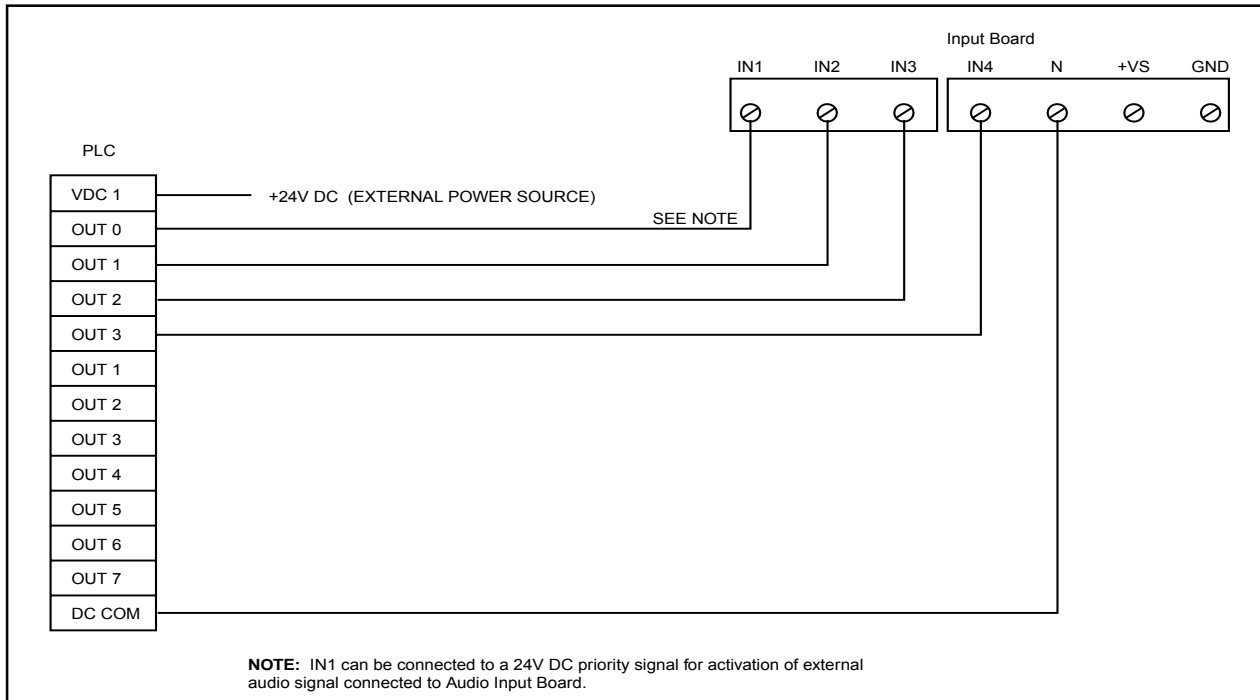

Figure 16. Connecting 24V Input Board of Tone Generator to a PLC
See Table 1

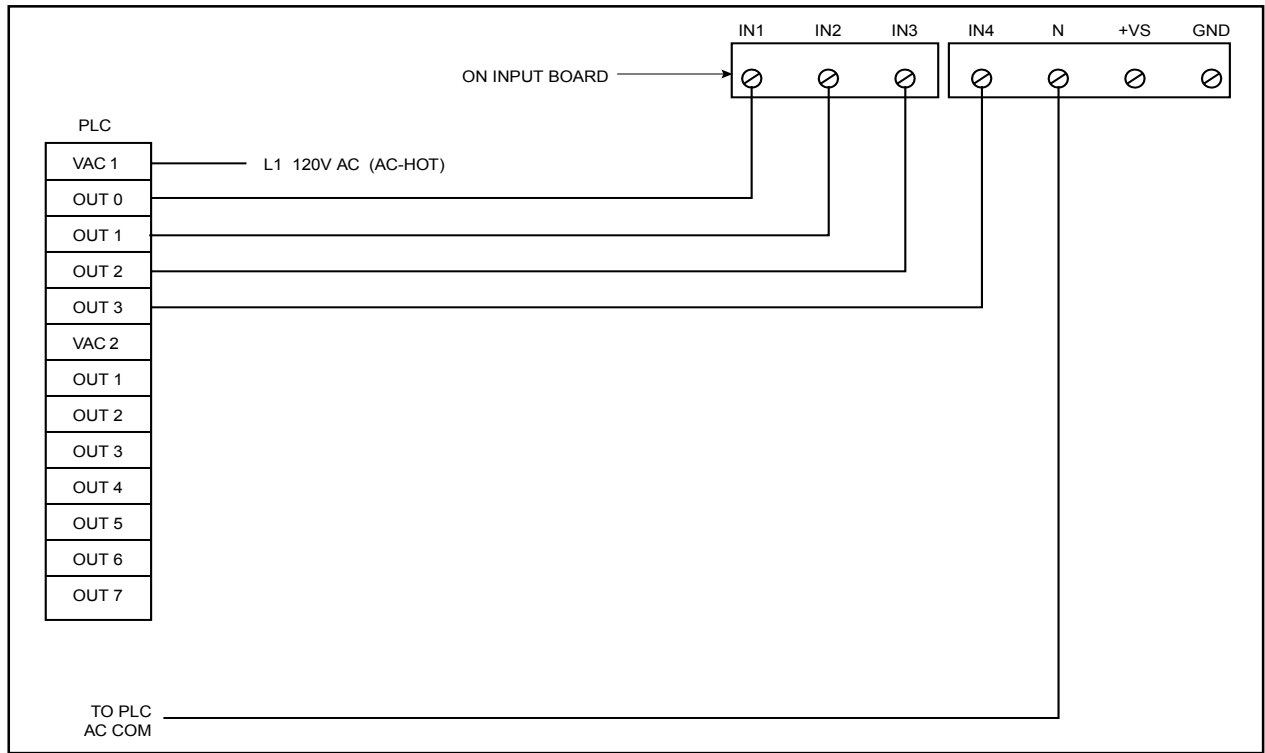

Figure 17. Connecting from a PLC to 120V Tone Generator Input Board
See Table 1

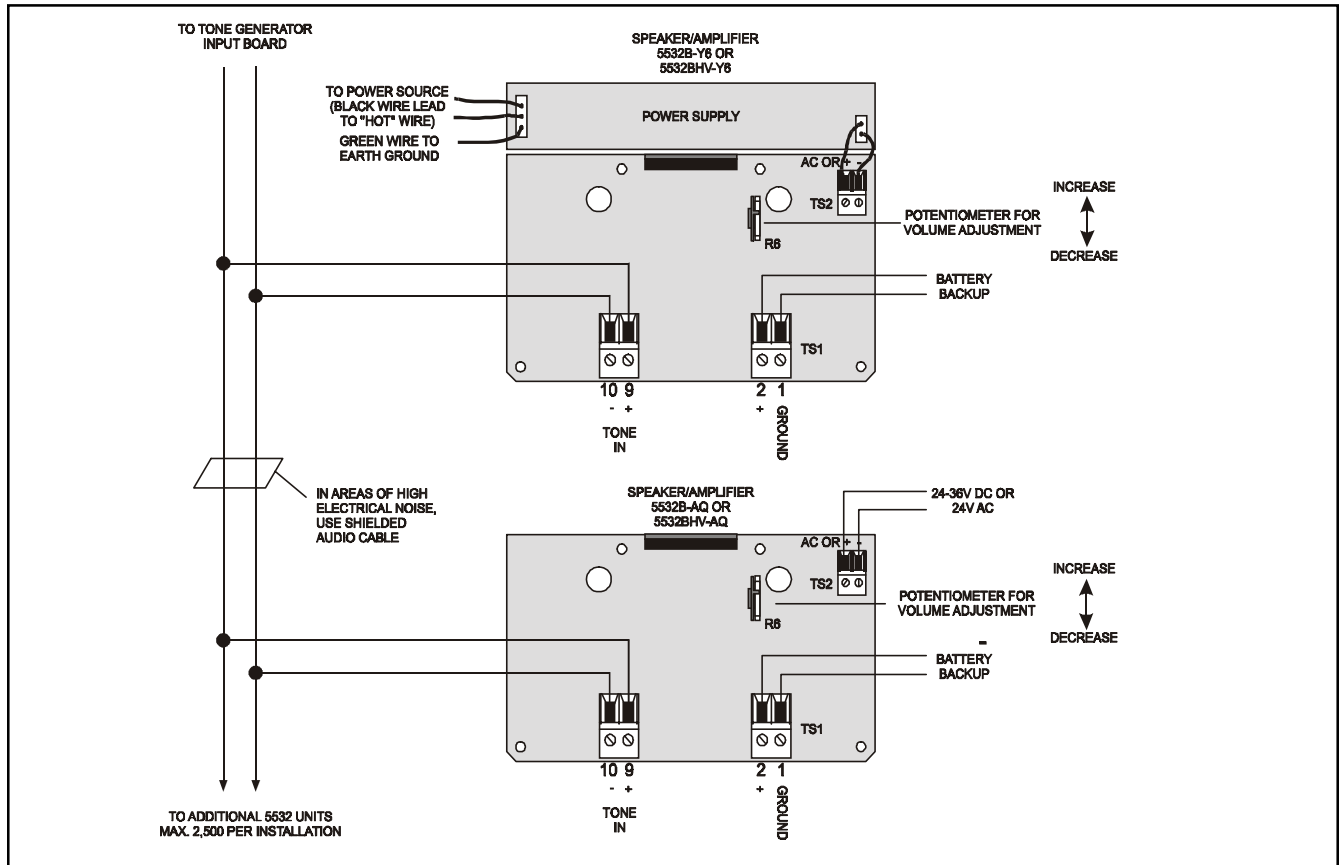

Figure 18. Connecting to the 5532B Series Speaker/Amplifiers

Figure 19. Tone Programming

Tone	Description	Switch					HEX
		1	2	3	4	5	
No Tone		○	○	○	○	○	00
Ding-Dong	Percussive pairs of 700 and 570 Hz tones, each damped to zero	●	○	○	○	○	01
Warble	575 and 770 Hz alternately, 87 ms each	○	●	○	○	○	02
Siren	600-1250 Hz up and down sweep in 8 seconds and repeat	●	●	○	○	○	03
Stutter	Percussive 470 Hz, 83 ms on, 109 ms off	○	○	●	○	○	04
Slow Whoop	600-1250 Hz upward sweep in 4 seconds and repeat	●	○	●	○	○	05
Beep	470 Hz, 0.55 seconds on, 0.55 seconds off	○	●	●	○	○	06
Chime 1	700 Hz percussive repeat at 1 Hz	●	●	●	○	○	07
Fast Whoop	600-1250 Hz upward sweep in 1 second and repeat	○	○	○	●	○	08
Hi/Lo	780 to 600 Hz alternately, 0.52 seconds each	●	○	○	●	○	09
Rapid Siren	600-1250 Hz up and down sweep in 0.25 seconds and repeat	○	●	○	●	○	0A
Yeow	1250-600 Hz downward sweep in 1.6 seconds and repeat	●	●	○	●	○	0B
Horn	470 Hz continuous	○	○	●	●	○	0C
Air Horn	370 Hz continuous	●	○	●	●	○	0D
Dual Tone	450-500 Hz, 0.4 to 0.5 second cycle	○	●	●	●	○	0E
Chime 2	575 Hz percussive repeat at 1 Hz	●	●	●	●	○	0F
Westminster	Two measures, 411 Hz, 520 Hz, 407 Hz, 312 Hz	○	○	○	○	●	10
Three Blind Mice	Four measures, 787 Hz, 714 Hz, 625 Hz, 952 Hz, 333 Hz	●	○	○	○	●	11
Phasor	416-625 Hz up and down sweep in 13 ms and repeat	○	●	○	○	●	12
Telephone	570 and 770 Hz alternately, 50 ms each for 1.2s, 1.5s delay and repeat	●	●	○	○	●	13
Staircase	440-2000 Hz up and down steps, 750 ms delay and repeat	○	○	●	○	●	14
3 Tone Alert	463, 641 and 896 Hz, 200 ms each, 1 second delay and repeat	●	○	●	○	●	15
Presignal Chime	470 Hz percussive repeat at 1.5 Hz, followed by Message 1	○	●	●	○	●	16
Message 1	Field recorded voice message	●	●	●	○	●	17
Message 2	Field recorded voice message	○	○	○	●	●	18
Message 3	Field recorded voice message	●	○	○	●	●	19
Message 4	Field recorded voice message	○	●	○	●	●	1A
NFPA Whoop	Three 422-775 Hz upward sweeps, 850 ms each, 1s delay and repeat	●	●	○	●	●	1B
3 Pulse Horn	470 Hz, 3 0.5 second pulses separated by 0.5 seconds followed by a 1.5 second delay and repeat-- For Evacuation Use Only	○	○	●	●	●	1C
3 Pulse Air Horn	370 Hz, 3 0.5 second pulses separated by 0.5 seconds followed by a 1.5 second delay and repeat-- For Evacuation Use Only	●	○	●	●	●	1D
3 Pulse Dual Tone	450-500 Hz, 0.4 to 0.5 second cycle, 3 0.5 second pulses separated by 0.5 seconds followed by a 1.5 second delay and repeat-- For Evacuation Use Only	○	●	●	●	●	1E
3 Pulse Chime 2	575 Hz, 3 0.5 second pulses separated by 0.5 seconds followed by a 1.5 second delay and repeat-- For Evacuation Use Only	●	●	●	●	●	1F



CAUTION

The use of evacuation signals on this product, that is not specifically Listed for Fire Alarm Use, is subject to the approval of the Authority Having Jurisdiction.